

Dutchwest

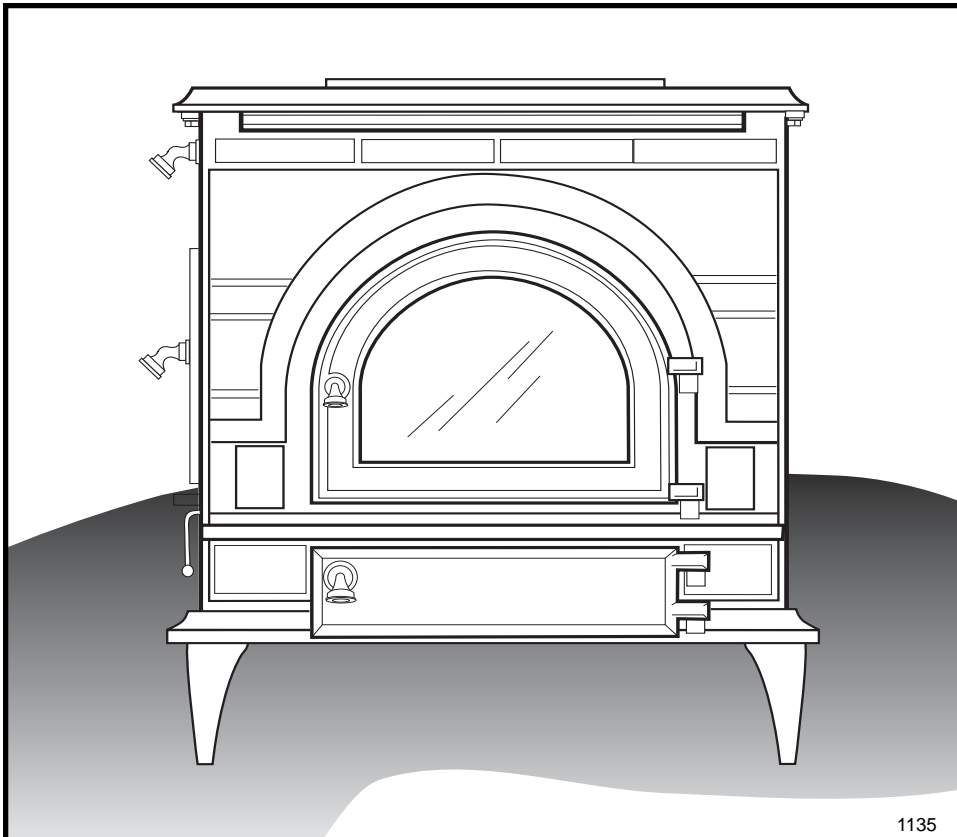

Convection Heater Model 2460, 2461, 2462

Homeowner's Installation and Operating Manual

SAFETY NOTICE

If this heater is not properly installed, operated, and maintained, a house fire may result. For safety, follow all installation, operation and maintenance directions. Contact local building officials about restrictions and installation inspection requirements in your area.

DO NOT DISCARD THIS MANUAL: Retain for future use



The Dutchwest models covered in this Owner's Guide have been tested and listed by Inchcape Testing Services / Warnock Hersey of Middleton, Wisconsin. The test standards utilized were ANSI/UL 1482 for the United States and CAN/CGA - B366.2 for Canada. Dutchwest models are not listed for mobile home installations.

PLEASE NOTE

Please read this entire manual before you install and use your new room heater. Failure to follow instructions may result in property damage, bodily injury or loss of life. Save these instructions for future use.

Table of Contents

Specifications	3
Installation	4
Clearances	12
Assembly	16
Operation	17
Maintenance	22
Illustrated Parts List	30

Accessories

- Bottom Heat Shield
- Clearance-reducing Rear Heat Shields
- Clearance-reducing Heat Shields for single-wall stove pipe
- 2" legs
- Warming shelves (Small and Large Heaters only)
- Two-speed convection blower
- Automatic thermostat for the blower

Proposition 65 Warning: Fuels used in gas, woodburning or oil fired appliances, and the products of combustion of such fuels, contain chemicals known to the State of California to cause cancer, birth defects and other reproductive harm.
California Health & Safety Code Sec. 25249.6

Patents: U.S. - D288357, 4502395, 4646712;
Canada - 1235969. Other foreign mechanical patents issued.

Specifications

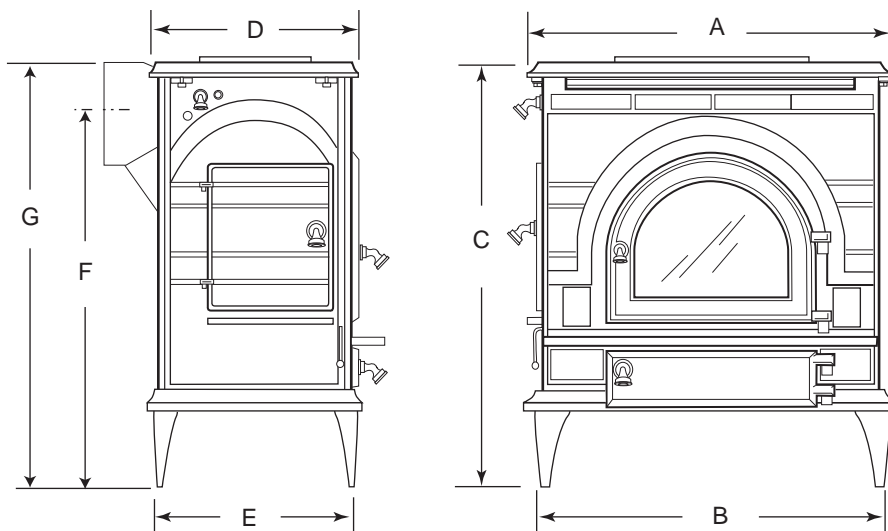

Stove Model Number	2460	2461	2462	1135
A	22" (560mm)	25 ³ / ₄ " (654mm)	28 ¹ / ₄ " (717mm)	
B	21" (530mm)	24 ¹ / ₂ " (620mm)	27" (690mm)	
C	29 ³ / ₄ " (754mm)	30" (760mm)	33" (840mm)	
D	16" (410mm)	16" (410mm)	18 ¹ / ₄ " (467mm)	
E	14 ³ / ₄ " (375mm)	14 ⁵ / ₈ " (380mm)	17" (430mm)	
F	26 ³ / ₄ " (683mm)	27" (690mm)	30 ¹ / ₈ " (763mm)	
G	29 ³ / ₄ " (754mm)	30" (760mm)	33" (840mm)	
Log length:	19" (480mm)	22" (560mm)	25" (640mm)	
Maximum burn time ¹ :	8 hrs.	9 hrs.	12 hrs.	
Average area heated (sq. ft.) ² :	700-1,400 (65-130m ²)	800-1,600 (75-150m ²)	1,200-2,400 (112-224m ²)	
Range of heat output ⁴ :	7,800 - 26,800 Btu/hr.	11,300 - 26,800 Btu/hr.	10,500-27,700 Btu/hr ⁵	
Maximum heat output:	35,000 Btu/hr.	40,000 Btu/hr.	55,000 Btu/hr.	
EPA emissions rating ⁴ (g/h, catalytic):	1.67	1.87	1.01	
Weight:	380 lbs. (172 kg)	436 lbs. (198 kg)	634 lbs. (288 kg)	
Loading:	Side or front	Side or front	Side or front	
Flue exit position (reversible):	Top or rear	Top or rear	Top or rear	
Air controls:	2 controls	2 controls	2 controls	

Fig. 1 Dutchwest Convection Heater specifications.

1. Maximum burn times and heat outputs are based on laboratory testing using full loads of seasoned hardwoods, and may vary in individual use depending on how the stove is operated, type and moisture content of fuels, and other factors. Maximum burn times are achieved under different operating conditions than are maximum heat outputs.

2. These values are based on operation in building code-conforming homes under typical Winter climate conditions in the northeastern U.S. If your home is of nonstandard construction (e.g. unusually well-insulated, not insulated, built underground, or if you live in a more severe or more temperate climate), these figures may not apply. Since so many variables affect performance, consult your Dutchwest Authorized Dealer to determine realistic expectations for your home.

4. Under specific conditions used during EPA emissions testing.

5. Based on preliminary results obtained during EPA emissions testing.

Installation

SAFETY NOTICE: IF YOUR DUTCHWEST CONVECTION HEATER IS NOT PROPERLY INSTALLED, OPERATED AND MAINTAINED, A HOUSE FIRE MAY RESULT. FOR SAFETY, FOLLOW ALL INSTALLATION, OPERATION AND MAINTENANCE DIRECTIONS. CONTACT LOCAL BUILDING OFFICIALS ABOUT RESTRICTIONS AND INSTALLATION INSPECTION REQUIREMENTS IN YOUR AREA.

Before you begin the installation, review your plans to confirm that:

- Your stove and chimney connector will be far enough from combustible material to meet all clearance requirements.
- The floor protector is large enough and is constructed properly to meet all requirements.
- You have obtained all necessary permits from local authorities.

Your local building official is the final authority for approving your installation as safe and for determining that it meets local and state codes.

Clearance and installation information is printed on the metal label attached to the rear of the stove. Local authorities generally will accept the label as evidence that, when the stove is installed according to the information on the label and in this manual, the installation meets codes and can be approved.

Codes vary in different areas, however. Before starting the installation, review your plans with the local building authority. Your local dealer can provide any additional information needed.

Important: Failure to follow these installation instructions may result in a dangerous situation, including a chimney or house fire. Follow all instructions exactly, and do not allow makeshift compromises to endanger property and personal safety.

Chimney Types

Your Dutchwest Convection Heater must be connected to a sound masonry chimney that meets local codes, a relined masonry chimney that meets local codes, or to an approved prefabricated metal chimney. Whatever kind you use, the chimney and chimney connector must be in good condition and kept clean.

Masonry Chimneys

If you use an existing masonry chimney, it must be inspected to ensure safe condition before the stove is installed. Your local professional chimney sweep, building inspector, or fire department official will be able either to make the inspection or to direct you to someone who can.

An inspection of the chimney must confirm that it has a lining. Do not use an unlined chimney. The chimney should also be examined for cracks, loose mortar, other signs of deterioration, and blockage. Repair any defects before the chimney is used with your stove.

Unused openings in an existing masonry chimney must be sealed with masonry to the thickness of the chimney wall, and the chimney liner should be repaired. Openings sealed with pie plates or wallpaper are a hazard and should be sealed with mortar or refractory cement. In the event of a chimney fire, flames and smoke may be forced out of these unused thimbles.

The chimney should be thoroughly cleaned before use.

A newly-built masonry chimney must conform to the standards of your local building code or, in the absence of a local code, to a recognized national code. Masonry chimneys must be lined, either with code-approved masonry or pre-cast refractory tiles, stainless steel pipe, or a code-approved, "poured-in-place" liner.

The chimney's clean-out door must seal tightly.

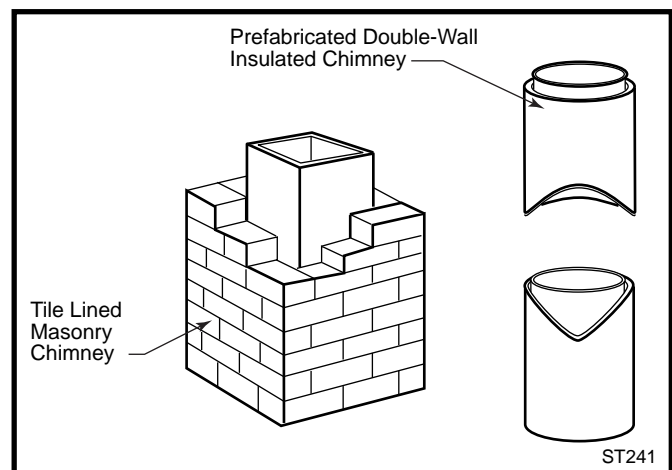

Fig. 2 If in sound condition and approved for use, either a masonry or a prefabricated chimney may be used.

Prefabricated Chimneys

A prefabricated metal chimney must be one tested and listed for use with solid-fuel burning appliances.

A horizontal connector run should be inclined 1/4" per foot (20 mm per meter) from the stove toward the chimney. The recommended maximum length of a horizontal run is 3 feet (1m) and the total length of chimney connector should be no longer than 8 feet (2.5m).

Chimney Height

For proper draft and good performance, the chimney should extend at least 16' (5 m) above the flue collar of the stove.

The chimney must also extend at least 3' (900 mm) above the highest point where it passes through a roof, and at least 2' (600 mm) higher than any portion of a building within 10' (3 m). (Fig. 2)

DO NOT CONNECT THIS UNIT TO A CHIMNEY FLUE SERVING ANOTHER APPLIANCE.

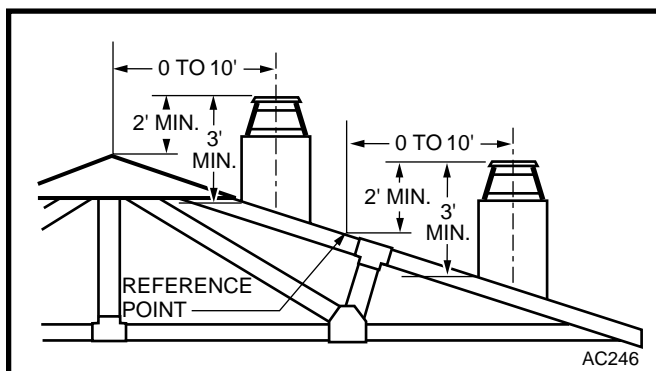

Fig. 3 The 2/3/10 rule for chimneys.

Chimney Size

The Model 2460 and 2461 heaters should be vented into a masonry chimney with a square flue with nominal flue size of 8" x 8" (200 x 200 mm), or a round flue with nominal flue size of 6" (150 mm). The Model 2462 heater should be vented into a masonry chimney with a nominal flue size of 8" x 8" (200 mm x 200 mm) square, or 8" (200 mm) round.

Chimney liners larger than 8" x 12" (200 x 300 mm) may promote rapid cooling of smoke and reduction in draft, especially if they are located outside the home. These large chimneys may need to be insulated or have their flues relined for proper stove performance.

Accessories to help make the connection between stainless steel chimney liners and the stove are available through your local dealer.

Guidelines For Installing The Chimney Connector

The chimney connector is the single-wall pipe, or listed and approved double-wall pipe that connects the stove to the chimney. The chimney itself is a masonry or prefabricated structure that encloses the flue. Chimney connectors are used only to make the connection from the stove to the chimney.

Do not pass the chimney connector through a combustible wall or ceiling, or through an attic, a closet or any similar concealed space. If passage through a combustible wall is unavoidable, follow the recommendations in the following section on Wall Pass-Throughs. Keep the passage as short and direct as possible, with no more than two 90 degree turns.

Two Types of Connector

You may use either a single-wall steel connector of the size and gauge described below, or a listed and approved double-wall connector.

Single-Wall Connector

The single-wall chimney connector should be made of 24 gauge or heavier steel, and must have a minimum internal diameter of 6" (150 mm) for models 2460 and 2461, or 8" (200 mm) for model 2462.

Install single-wall chimney connector not less than 18" (450 mm) from the ceiling.

In cathedral ceiling installations, extend the prefabricated chimney downward to within 8 feet (2.5 meters) of the stove. The entire chimney connector should be exposed and accessible for inspection and cleaning.

Do not use galvanized chimney connector; it cannot withstand the high temperatures that can be reached by smoke and exhaust gases and it may release toxic fumes under high heat.

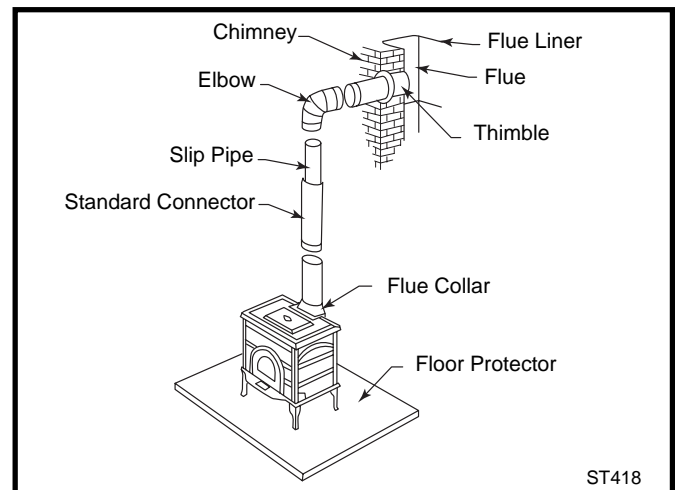

Fig. 4 Sections of a steel chimney connector of at least 24 gauge thickness are fastened together with screws to connect the stove to the chimney.

Double-Wall Connector

Information on assembling and installing double-wall connectors is provided by the manufacturer of the double-wall pipe. Follow the manufacturer's installation instructions exactly. Most manufacturers of prefabricated double-wall insulated chimneys also offer double-wall connector pipes. Using a chimney and connector pipe from the same manufacturer helps simplify the assembly and installation.

NOTE: For installations using double-wall connectors, minimum clearances must conform to listed clearances in the Stove and Chimney Connector Clearance Charts on page 12 and 13 of this manual.

Assembling Single-Wall Chimney Connector

SAFETY NOTE: Always wear gloves and safety goggles when drilling, cutting or joining sections of chimney connector.

For double-wall connectors, follow the manufacturer's instructions exactly. For single-wall connectors, follow the instructions below.

1. Insert the crimped end of the first section into the stove's flue collar, and keep each crimped end pointing toward the stove (Fig.5). Using the holes in the flue collar as guides, drill 1/8" (3 mm) holes in the bottom of the first section of chimney connector and secure it to the flue collar with three #10 x 1/2" sheet metal screws.

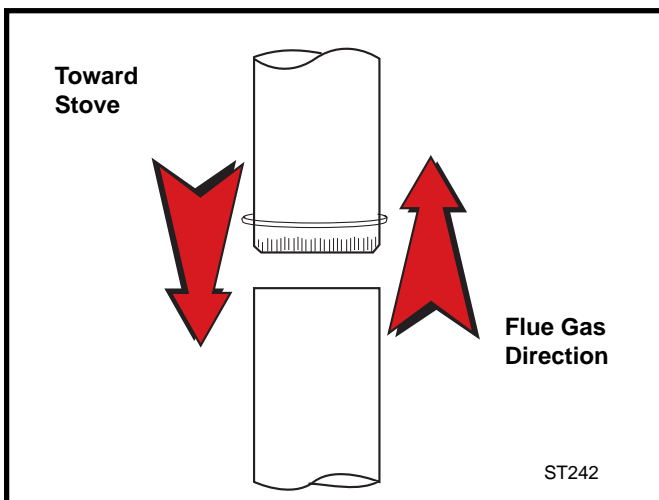

Fig. 5 Crimped sections always point toward the stove so that any liquid condensation will not leak out.

2. Secure each joint between sections of chimney connector, including telescoping joints, with at least three sheet metal screws.

3. Secure the chimney connector to the chimney. Instructions for various installations follow below.

4. Confirm that the installed stove and chimney connector are correct distances from nearby combustible material. See the clearance charts on pages 12 and 13.

NOTE: Special slip pipes and thimble sleeves that form telescoping joints between sections of chimney connector are available to simplify installations. They can eliminate the need to cut individual connector sections. Consult your local dealer about these special pieces.

Securing The Connector To A Prefabricated Chimney

Follow the installation instructions of the chimney manufacturer exactly as you install the chimney. The manufacturer of the chimney will supply the accessories to support the chimney, either from the roof of the house, at the ceiling of the room where the stove is installed, or from an exterior wall.

Special adaptors are available from your local dealer to make the connection between the prefabricated chimney and the chimney connector. (Fig. 6) The top of such adaptors attach directly to the chimney or to the chimney's ceiling support package, while the bottom of the adaptor is screwed to the chimney connector.

These adaptors are designed so the top end will fit outside the inner wall of the chimney, and the bottom end will fit inside the first section of chimney connector. Any soot or creosote falling from the inner walls of the chimney will stay inside the chimney connector.

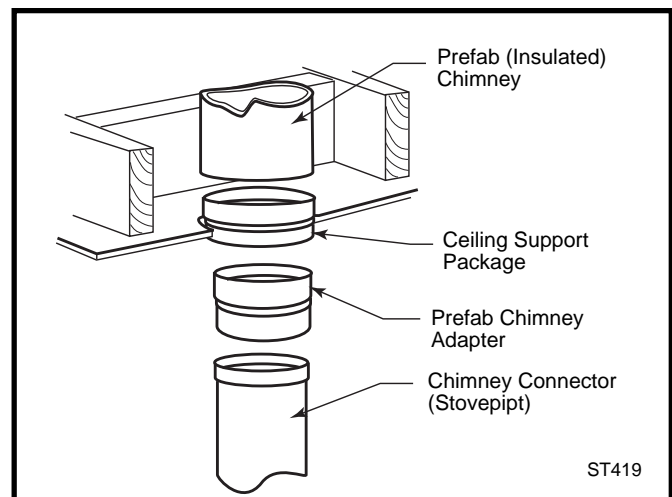

Fig. 6 Joining the chimney connector to a prefabricated chimney.

Securing The Connector To A Masonry Chimney

The Dutchwest Convection heaters may be connected to either a freestanding masonry chimney or a masonry fireplace chimney.

Freestanding Installations

If the chimney connector must pass through a combustible wall to reach the chimney, follow the recommendations in the wall pass-through section that follows.

The opening through the chimney wall to the flue (the "breach") must be lined with either a ceramic or metal cylinder, called the "thimble", which is securely cemented in place. (Fig. 7) Most chimney breeches incorporate thimbles, but check to be sure the fit is snug and the joint between thimble and chimney wall firmly cemented.

A special piece called the "thimble sleeve," slightly smaller in diameter than the standard connector and most thimbles, will ease the removal of the chimney connector system for inspection and cleaning. Thimble sleeves should be available from your local dealer.

To install a thimble sleeve, slide it into the breach until it is flush with the inner flue wall. Don't extend it into the actual flue passage, as that could interfere with the draft.

The thimble sleeve should protrude 1-2" (25-50 mm) into the room. Use furnace cement and thin gasketing to seal the sleeve in place in the thimble. Secure the chimney connector to the outer end of the sleeve with sheet metal screws.

Fireplace Installations - Above the Fireplace

In this installation, the chimney connector rises from the stove, turns ninety degrees, and goes back into the fireplace chimney. The liner of the fireplace chimney should extend at least to the point at which the chimney connector enters the chimney. Follow all the guidelines for installing a chimney connector into a freestanding masonry chimney, and pay special attention to these additional points:

- Check the stove and chimney connector clearances to combustible mantel or trim materials. Use the necessary combination of mantel, trim, and connector heat shields to provide the required clearances. (Fig. 8)
- Double-check connector clearance from the ceiling.
- The fireplace damper must be closed and sealed to prevent room air from being drawn up the flue, reducing the draft. However, it must be possible to re-open the damper to inspect or clean the chimney.

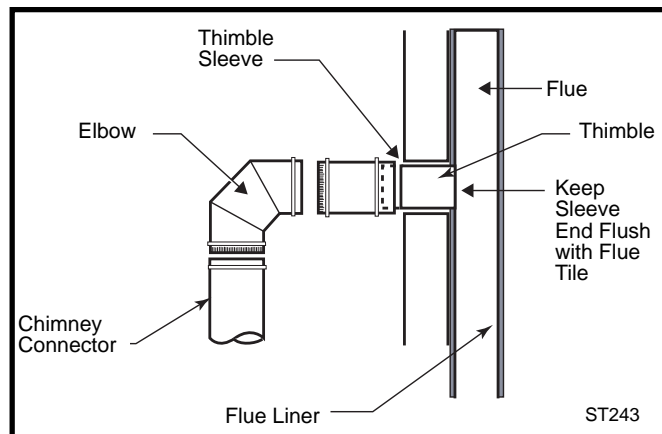

Fig. 7 The thimble, made of either ceramic or metal, must be cemented in place securely.

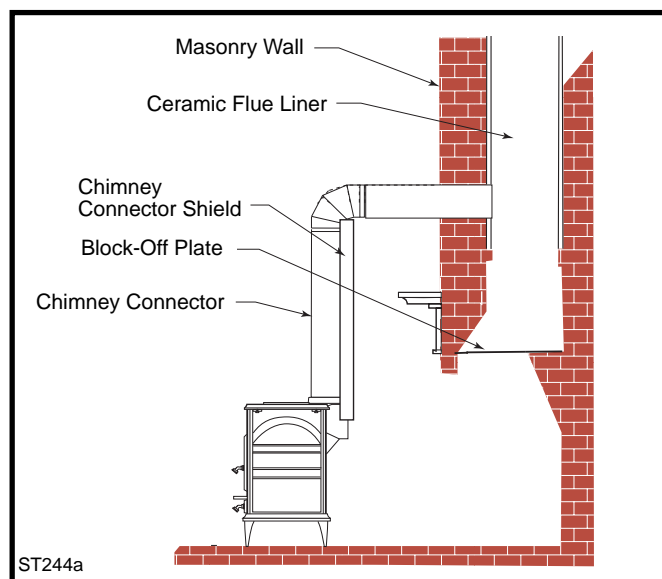

Fig. 8 The connector enters flue above the fireplace. If the clearance between the chimney connector and either the mantel and/or the ceiling is inadequate, special protective shields will be required.

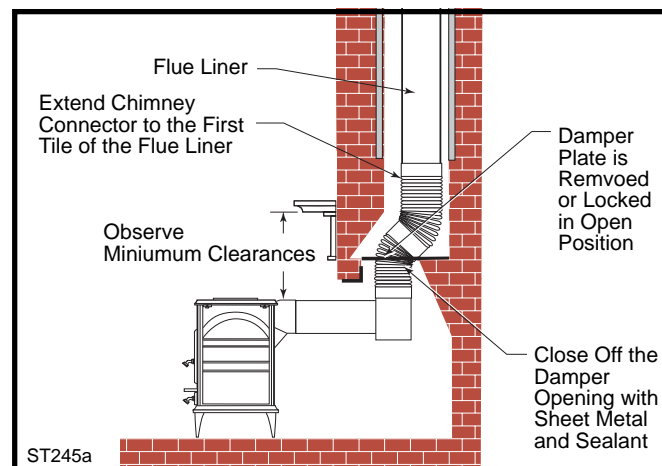

Fig. 9 The connector passes through the fireplace to enter flue. Special Fireplace Adapter Kits to simplify fireplace installations are available from your local dealer.

Fireplace Installations - Through the Fireplace

The Convection heaters may be installed either without legs* as a fireplace insert, or with standard legs attached - depending on the safety regulations that apply to your situation, the height of the fireplace opening and your own preference. For either situation, the chimney connector/positive connection kit extends back from the stove, enters the fireplace cavity, and turns upward. It then passes through the fireplace damper opening and smoke chamber and connects to the chimney flue.

In such installations, a "positive connection" must be made to the chimney flue with a special kit available from your local dealer. Also, special clearance and floor protection provisions must be observed. These provisions are discussed in the Clearance and Floor Protection sections respectively.

Wall Pass-Throughs

Whenever possible, design your installation so the connector does not pass through a combustible wall. If you must use a wall pass-through in your installation, check with your building inspector before you begin and construct it in accordance with local building codes. Also check with the chimney connector manufacturer for any specific requirements.

Accessories are available for use as wall pass-throughs. If using one of these, make sure it has been tested and listed for use as a wall pass-through.

All combustible material in the wall is cut away a sufficient distance from the single-wall connector to provide the required 12" (305 mm) clearance for the connector. Any material used to close up the opening must be noncombustible.

The following wall pass-through methods may be approved in your area:

- Use a section of listed factory-built chimney with a nine-inch clearance to combustibles.
- Place a chimney connector pipe inside a ventilated thimble, which is then separated from combustibles by six inches (152 mm) of fiberglass insulating material.
- *If the stove is installed without legs, we recommend the use of noncombustible tiles or pavers as shims to allow air flow into the convection air inlets under the stove. Make sure not to block air slots instove bottom with shims or remove fan cover.*
- Place a chimney connector pipe inside a section of listed solid-insulated, factory-built chimney, with an inside diameter 2 inches (51 mm) larger than the

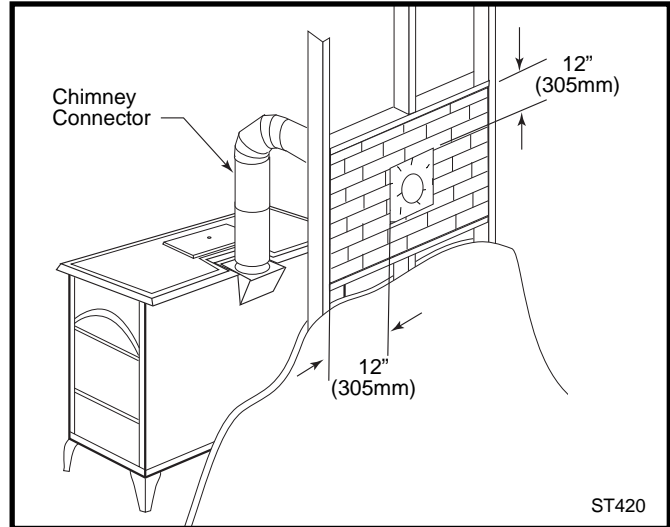

Fig. 10 Wall pass-through enclosed with noncombustible materials.

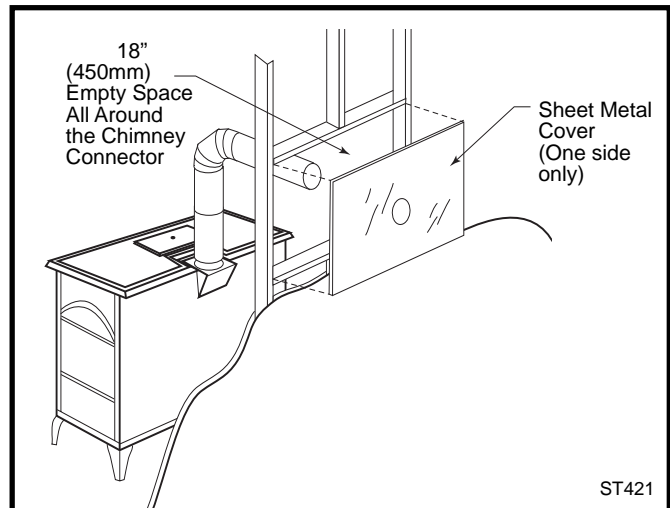

Fig. 11 Hollow wall pass-through.

chimney connector and having 1 inch (25.4 mm) or more of insulation and maintaining a minimum 2 inch air space between the outer wall of the chimney and combustibles.

DO NOT CONNECT THE HEATER TO ANY AIR DISTRIBUTION DUCT OR SYSTEM.

In Canada: The Canadian Standards Association has established different guidelines. Figure 11 shows one method, in which all combustible material in the wall is cut away to provide the required 18" (450 mm) clearance for the connector. The resulting space must remain empty.

A flush-mounted sheet metal cover may be used on one side only. If covers must be used on both sides, each cover must be mounted on non-combustible spacers at least 1" (25 mm) clear of the wall. Your Dutchwest dealer or your local building inspector can provide details of other approved methods of passing a chimney connector through a combustible wall. In Canada, this type of installation must conform to CAN/CSA-B365, Installation Code for Solid Fuel Burning Appliances and Equipment.

NOTE: Do not vent your Dutchwest stove into a factory-built (zero-clearance) fireplace. These appliances and their chimneys are specifically designed as a unit for use as fireplaces. It may void the listing or be hazardous to adapt them for any other use.

Floor Protection

A tremendous amount of heat radiates from the bottom plate of your Dutchwest stove. The floor area directly under and around the stove will require protection from radiant heat as well as from stray sparks or embers that may escape the firebox.

Heat protection is provided through the use of a Vermont Castings Bottom Heat Shield. Spark and ember protection must be provided by a floor protector constructed with noncombustible material as specified. Most installations will require that the bottom heat shield be attached. Only when the stove is placed on a completely noncombustible surface such as unpainted concrete over earth may it be used without the heat shield.

Even when the bottom heat shield is installed, you must provide special protection to the floor beneath. For installation with the heat shield attached, use a noncombustible floor protector such as 1/4" non-asbestos mineral board or equivalent, or 24 gauge sheet metal. The floor protector may be covered with a decorative noncombustible material if desired. Do not obstruct the space under the heater.

Protection requirements vary somewhat between the United States and Canada as follows:

U.S. Installations: The floor protector is required under the stove and must extend at least 16 inches from the front and left (loading door) side of the stove, and at least 6 inches from the right side and rear. (Fig. 12) Refer to Figure 12 for minimum noncombustible floor protection dimensions for each stove model.

In Canada: a noncombustible floor protector is required under the heater also. The floor protector must extend 18 inches (457mm) from the front and left (loading door) side of the stove, and at least 8 inches (203mm) from the right side and rear. (Fig. 12)

Due to the side loading door, floor protector requirements call for more protection on the left side than on

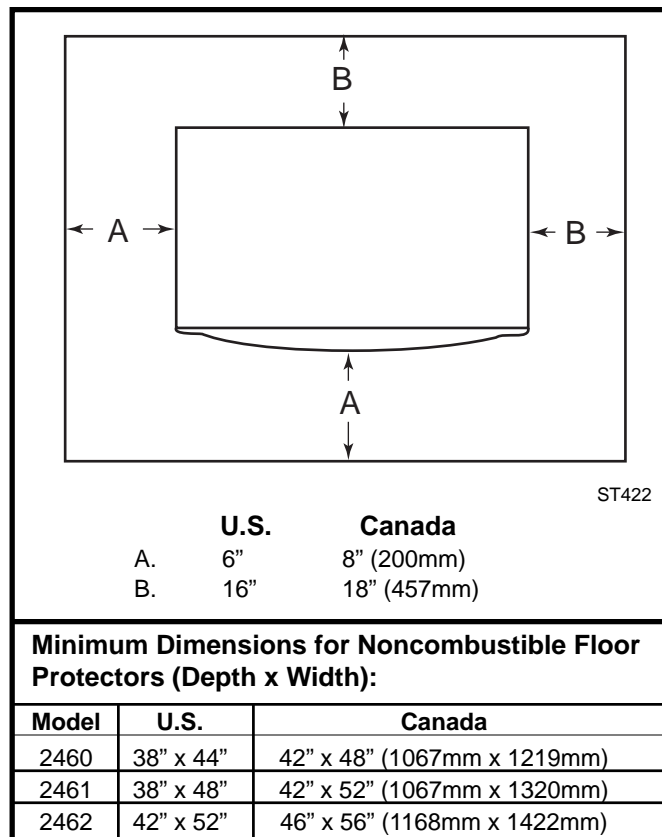

Fig. 12 Be sure to follow exactly the floor protection requirements on all four sides of the stove.

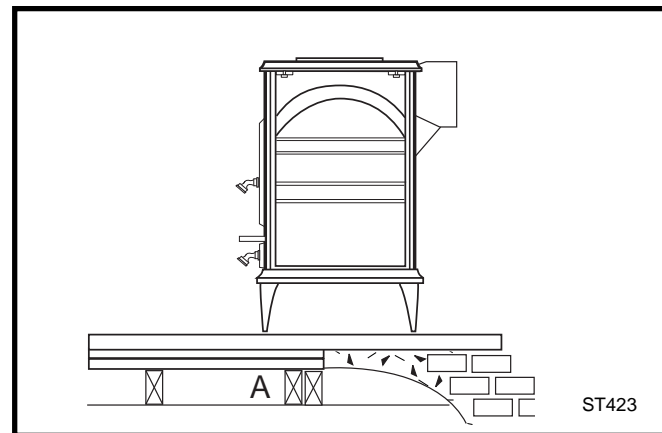

Fig. 13 Combustible supporting timbers (A) may lie beneath fireplace hearths; such situations require additional floor protection.

the right. If you wish a more balanced look, increase the other side of the hearth as well. **Do not reduce side protection under any circumstances.**

Fireplace Installations

You may install your Dutchwest Convection Heater in an existing fireplace as a fireplace insert with no legs,* or with the standard legs attached.

To install the heater without legs as a fireplace insert, the floor must be completely noncombustible, such as an unpainted concrete floor over earth.

Many fireplaces do not satisfy the “completely noncombustible” requirement because the brick or concrete hearth in front of the fireplace opening usually is supported by heavy wooden framing as in Figure 13. Because heat passes readily through brick or concrete, it can easily pass through to the wood. As a result, such fireplace hearths are considered a combustible floor.

You may not install a heater on a combustible hearth without legs. Standard leg installations must include the bottom heat shield. The floor protector must also meet standard requirements for freestanding installations.

Floor Protection for Fireplace Installations with Standard Legs

Fireplace installations with the standard legs and the bottom heat shield must have a floor protector of the same construction as that specified for freestanding installations: 1/4" non-asbestos mineral board or equivalent, or 24 gauge sheet metal (that may be covered with a decorative noncombustible material if you desire). The floor protector must extend at least 16" (406 mm) [18" / 457 mm in Canada] from the front of the stove and from the left (loading door) side, and at least 6" (152 mm) from the right side and rear. It must also provide protection beneath any horizontal runs of the chimney connector, including 2" to either side.

Many raised hearths will extend less than the required distance from the front of the heater when it is installed. In such cases, sufficient floor protection, as described above, must be added to extend the hearth 16" (406 mm) [18" (457 mm) in Canada].

Hearth rugs do not satisfy the requirements for floor protection.

Fireplace insert installations also have specific clearance requirements to the side walls, side decorative trim, and fireplace mantel. This information is found in “Fireplace Installation Clearances” in this section.

REMINDER- FIREPLACE INSERT INSTALLATIONS WITHOUT LEGS ARE PERMISSIBLE ONLY IF THE HEARTH IS COMPLETELY NONCOMBUSTIBLE, SUCH AS UNPAINTED CONCRETE OVER EARTH.

Keep The Stove A Safe Distance From Surrounding Materials

Both a stove and its chimney connector radiate heat in all directions when operating. A safe installation requires that adequate *clearance* be maintained between the stove and nearby combustible materials to ensure that such materials do not overheat.

Clearance is the distance between either your stove or chimney connector, and nearby walls, floors, the ceiling, and any other fixed combustible surface. Keep furnishings and other combustible materials away from the stove as well. In general, a distance of 48" (1220 mm) must be maintained between the stove and moveable combustible items such as drying clothes, furniture, newspapers, firewood, etc. Keeping those clearance areas empty assures that nearby surfaces and objects will not overheat.

Safe Ways To Reduce Clearances

Your stove has specific clearance requirements that have been established through careful research and testing to UL and ULC standards.

Clearance requirements have been established to meet every installation possibility, and they involve the combination of basic variables:

- When the stove *has no* listed heat shield
- When the stove *has* a listed heat shield
- When the wall *has no* heat shield
- When the wall *has* a heat shield
- When the stove *has* a double-wall chimney connector.
- When the stove has a single-wall connector with heat shields, or without heat shields.

In general, the greatest clearance is required when you locate a stove with no heat shield near a wall with no heat shield. The least clearance is required when both the stove and the wall have heat shields. Reducing a stove clearance may require a listed heat shield on the chimney connector as well, or a double-wall connector.

Clearances may be reduced only by means approved by the regulatory authority and in accordance with the clearances listed in this manual. The charts and sample installations that follow list all the clearances required for the various installation configurations of Dutchwest Convection Heaters.

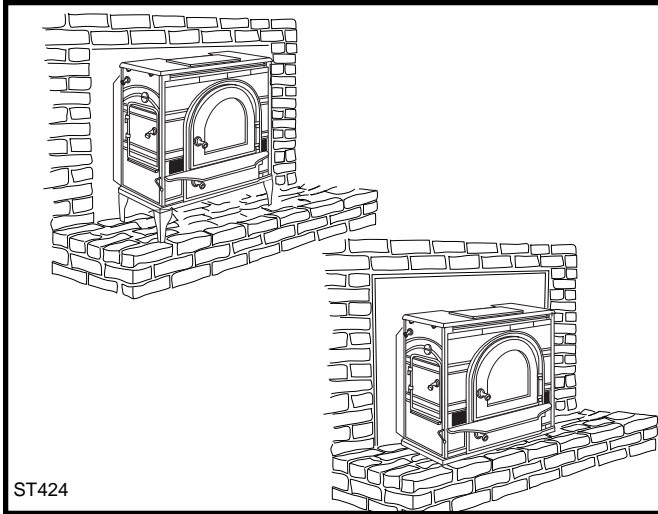

Fig. 14 Extra floor protection may be required for the fireplace hearth, even if your stove is installed with the legs and the bottom heat shield.

Fireplace Installation Clearances

A fireplace installation requires special clearance between the:

- Side of the stove and the right and left walls
- Side of the stove and the decorative side trim on the fireplace face
- Top of the stove and the mantel

In addition, both Fireplace Adaptor and Fireplace Insert installations have special floor protection requirements that are addressed in the section on Floor Protection.

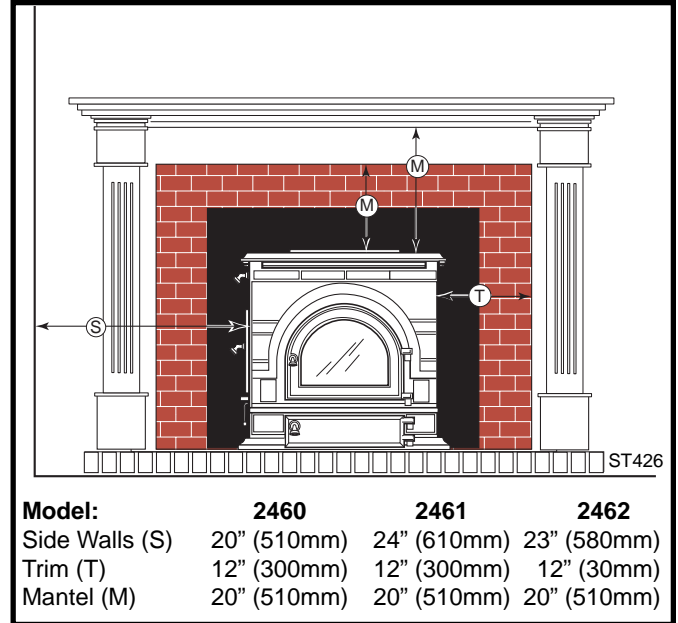

Fig. 15 Minimum clearances for fireplace installation. Recommended clearances must be maintained between stove and the surrounding combustible components.

Designing a Safe Installation

The section that follows contains charts with the information that you'll need to make your installation safe. Included are a chart to tell you exactly where to cut the hole in the ceiling so that the stove will meet clearance requirements, a chart that gives stove clearances for all installations, and a chart to illustrate the required sizes of wall shields for various installations.

Refer to these charts as you plan the installation and do not compromise on any of the dimensions listed.

Clearance Chart Reference Diagrams

Refer to the diagrams below when using the Stove and Chimney Connector Clearance Chart which follows. For example, the letter "A" gives the minimum side clearance for installations in which the stove is not equipped with a rear heat shield and the wall beside the stove is not protected. "D" gives the minimum side clearance when the stove does not have a rear heat shield, but the wall is protected.

Measure clearance distances from the top plate of the stove or chimney connector to the wall, not the wall protector.

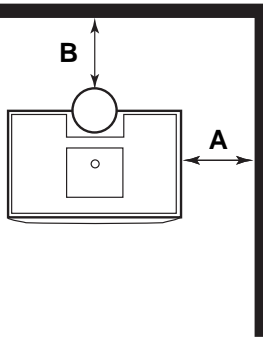
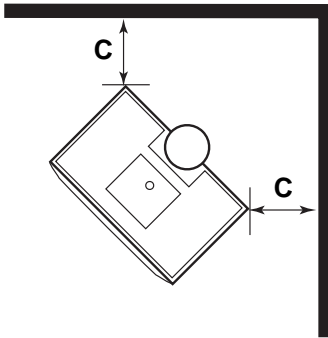
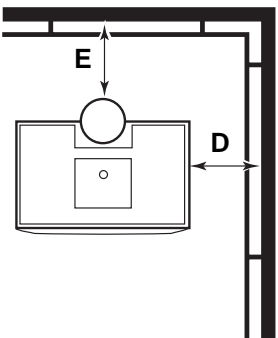
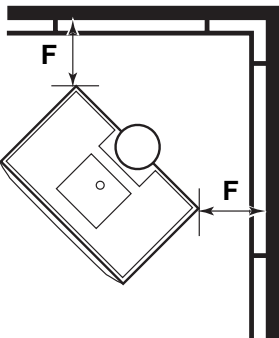
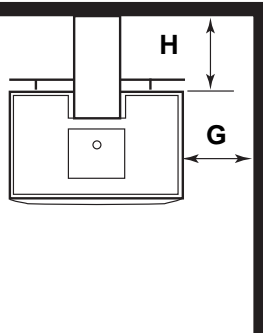
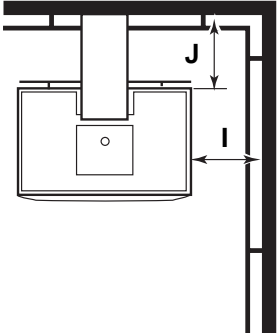
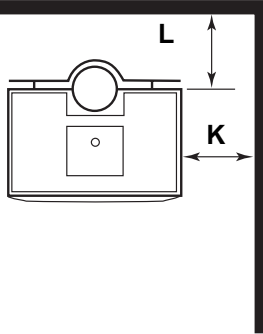
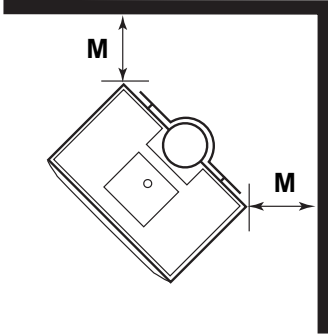
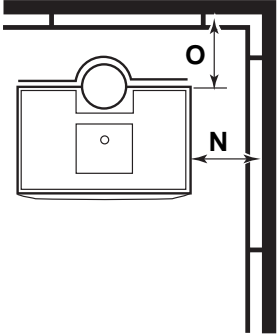
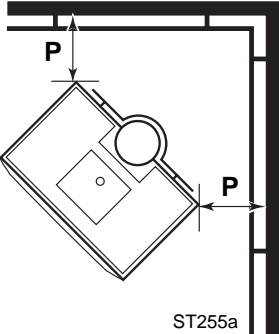
Unprotected Surfaces		Protected Surfaces	
Parallel Installations	Corner Installations	Parallel Installations	Corner Installations
			
Installations with no stove heat shields			
	N/A		N/A
Rear exit, rear heat shield installations			
			
Top exit, rear heat shield and chimney connector heat shields or double wall connector			

ST255a

Stove and Chimney Connector Clearance Charts

Model 2460 Small Convection, and Model 2461 Large Convection:

UNPROTECTED SURFACES				PROTECTED SURFACES		
Parallel Installations			Corner Installations	Parallel Installations		Corner Installations
Stove Clearance	Side	Rear	Corner	Side	Rear	Corner
No heat shields	[A] 22" (560 mm)	[B] 24" (610 mm)	[C] 18" (460 mm)	[D] 12" (300 mm)	[E] 14" (360 mm)	[F] 10" (250 mm)
Rear exit, rear h.s.	[G] 22" (560 mm)	[H] 14" (360 mm)	N/A	[I] 12" (300 mm)	[J] 12" (300 mm)	N/A
Top exit ¹ , rear h.s. Single-wall connector No connector h.s.	[K] 22" (560 mm)	[L] 24" (610 mm)	[M] 18" (460 mm)	[N] 12" (300 mm)	[O] 14" (360 mm)	[P] 10" (250 mm)
Top exit ^{1,2} , rear h.s. Single-wall connector with connector h.s.	[K] 22" (560 mm)	[L] 14" (360 mm)	[M] 15" (380 mm)	[N] 12" (300 mm)	[O] 12" (360 mm)	[P] 8" (200 mm)
Top exit ¹ , rear h.s. Double-wall connector	[K] 22" (560 mm)	[L] 19" (480 mm)	[M] 15" (380 mm)	[N] 12" (300 mm)	[O] 11" (280 mm)	[P] 8" (200 mm)
Chimney Connector Clearance:						
Single-wall connector No connector h.s.		19" (480 mm)		9" (230 mm)		
Single-wall ² connector With connector h.s.		9" (360 mm)		7" (180 mm)		
Double-wall connector		14" (360 mm)		6" (150 mm)		
Front Clearance to Combustibles:				48" (1220 mm) (All Installations)		

Model 2462 Extra-Large Convection:

UNPROTECTED SURFACES				PROTECTED SURFACES		
Parallel Installations			Corner Installations	Parallel Installations		Corner Installations
Stove Clearance	Side	Rear	Corner	Side	Rear	Corner
No heat shields	[A] 20" (510 mm)	[B] 23" (580 mm)	[C] 18" (460 mm)	[D] 18" (460 mm)	[E] 18" (460 mm)	[F] 17" (430 mm)
Rear exit, rear h.s.	[G] 20" (510 mm)	[H] 18" (460 mm)	N/A	[I] 18" (460 mm)	[J] 12" (300 mm)	N/A
Top exit ¹ , rear h.s. Single-wall connector No connector h.s.	[K] 20" (510 mm)	[L] 23" (580 mm)	[M] 18" (460 mm)	[N] 18" (460 mm)	[O] 18" (460 mm)	[P] 17" (430 mm)
Top exit ^{1,2} , rear h.s. Single-wall connector with connector h.s.	[K] 20" (510 mm)	[L] 18" (460 mm)	[M] 17" (430 mm)	[N] 18" (460 mm)	[O] 12" (300 mm)	[P] 15" (380 mm)
Top exit ¹ , rear h.s. Double-wall connector	[K] 20" (510 mm)	[L] 14" (360 mm)	[M] 16" (410 mm)	[N] 18" (460 mm)	[O] 12" (300 mm)	[P] 15" (380 mm)
Chimney Connector Clearance:						
Single-wall connector No connector h.s.		18" (460 mm)		13" (330 mm)		
Single-wall ² connector With connector h.s.		13" (330 mm)		7" (180 mm) ^{3,4}		
Double-wall connector		8" (200 mm)		6" (150 mm)		
Front Clearance to Combustibles:				48" (1220 mm) (All Installations)		

1 Shielding for a top exit stove must include a shield insert to protect the area behind the flue collar.

2 Chimney connector heat shields must extend exactly 24" (610 mm) above the flue collar of the stove.

3 All installations venting straight up to a factory built chimney require a 24" (610 mm) diameter or square ceiling heat shield. The ceiling heat shield should be 24 gauge sheet metal or equivalent mounted on 1" (25 mm) non-combustible spacers 1" (25 mm) below ceiling.

4 Chimney connector heat shields must extend to within 1" (25 mm) or less of the ceiling heat shield for installations venting straight up to a factory-built chimney. In top exit installations using an elbow to vent to the rear, the chimney connector must be shielded over the entire vertical length.

5 If a single-wall oval-to-round adaptor is used, a shield must be used to protect combustibles to the rear of the adaptor.

Distance from Center of Flue Collar to Wall in Top-Exit Installations

Dutchwest Convection Heaters equipped with rear heat shields

NOTE: These are not clearance distances. These measurements indicate where the centerline of the flue collar will be for various installations. Measurements are from the centerline of the flue collar to the wall, not the wall protector.

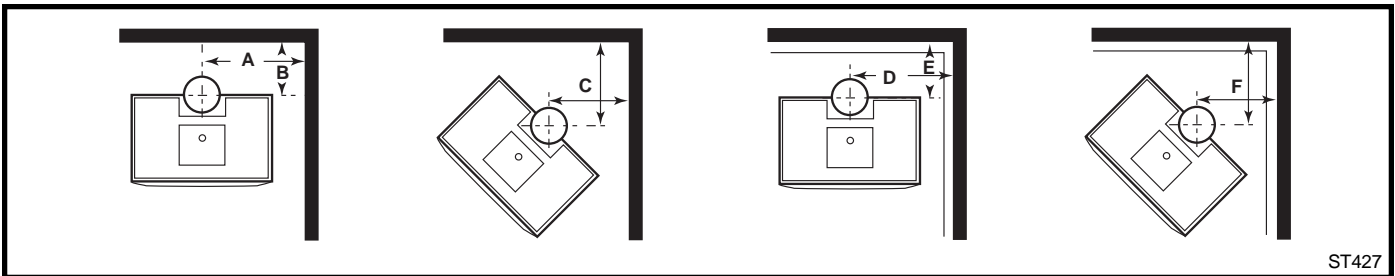

ST427

	UNPROTECTED SURFACES			PROTECTED SURFACES		
	Parallel Installations		Corner Installations	Parallel Installations		Corner Installations
	Side	Rear	Corner	Side	Rear	Corner
Chimney Connector						
MODEL 2460 (Small Convection)						
Listed, Approved Double-wall	[A] 33" (840 mm)	[B] 18" (460 mm)	[C] 25" (640 mm)	[D] 23" (580 mm)	[E] 10" (250 mm)	[F] 15" (380mm)
Single Wall, with Connector Heat Shields	[A] 33" (840 mm)	[B] 13" (330 mm)	[C] 22" (560 mm)	[D] 23" (580 mm)	[E] 11" (580 mm)	[F] 15" (380 mm)
Single Wall, without Connector Heat Shields	[A] 33" (840 mm)	[B] 23" (580 mm)	[C] 25" (640 mm)	[D] 23" (580 mm)	[E] 13" (330 mm)	[F] 17" (430 mm)
MODEL 2461 (Large Convection)						
Listed, Approved Double-wall	[A] 35" (890 mm)	[B] 18" (460 mm)	[C] 27" (690 mm)	[D] 25" (640 mm)	[E] 10" (250 mm)	[F] 17" (430 mm)
Single Wall, with Connector Heat Shields	[A] 35" (890 mm)	[B] 13" (330 mm)	[C] 24" (610 mm)	[D] 25" (640 mm)	[E] 11" (280 mm)	[F] 17" (430 mm)
Single Wall, without Connector Heat Shields	[A] 35" (890 mm)	[B] 23" (580 mm)	[C] 27" (690 mm)	[D] 25" (640 mm)	[E] 13" (330 mm)	[F] 19" (480 mm)
MODEL 2462 (Extra-Large Convection)						
Listed Approved Double-Wall	[A] 35" (890 mm)	[B] 13" (330 mm)	[C] 26" (660 mm)	[D] 33" (660 mm)	[E] 11" (280 mm)	[F] 25" (640 mm)
Single Wall, with Heat Shields	[A] 35" (890 mm)	[B] 17" (430 mm)	[C] 29" (740 mm)	[D] 33" (840 mm)	[E] 11" (280 mm)	[F] 25" (640 mm)
Single Wall, without Heat Shields	[A] 35" (890 mm)	[B] 22" (560 mm)	[C] 33" (840 mm)	[D] 33" (840 mm)	[E] 17" (430 mm)	[F] 27" (690 mm)

Wall Heat Shield Dimensions

DutchWest Convection Heaters, Models #2460 (Small), #2461 (Large), and #2462 (Extra Large)

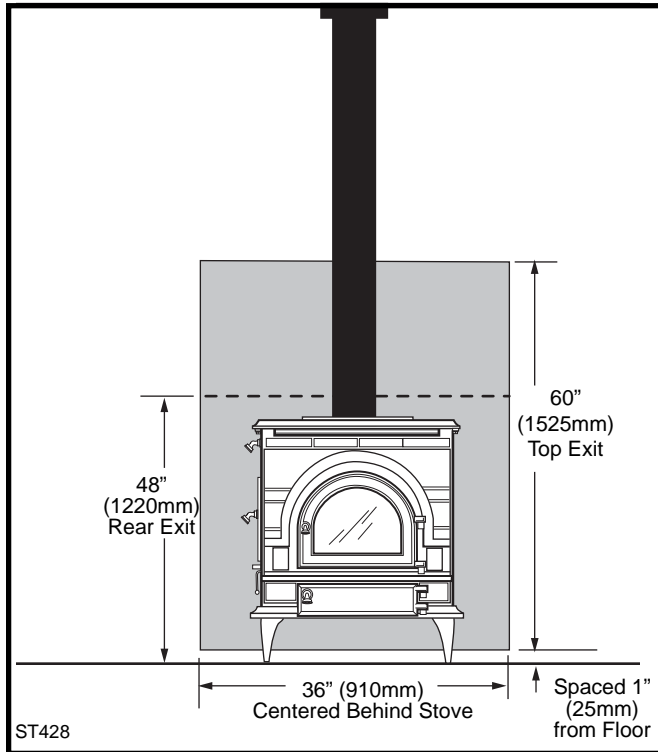

Fig. 16 Rear wall protection.

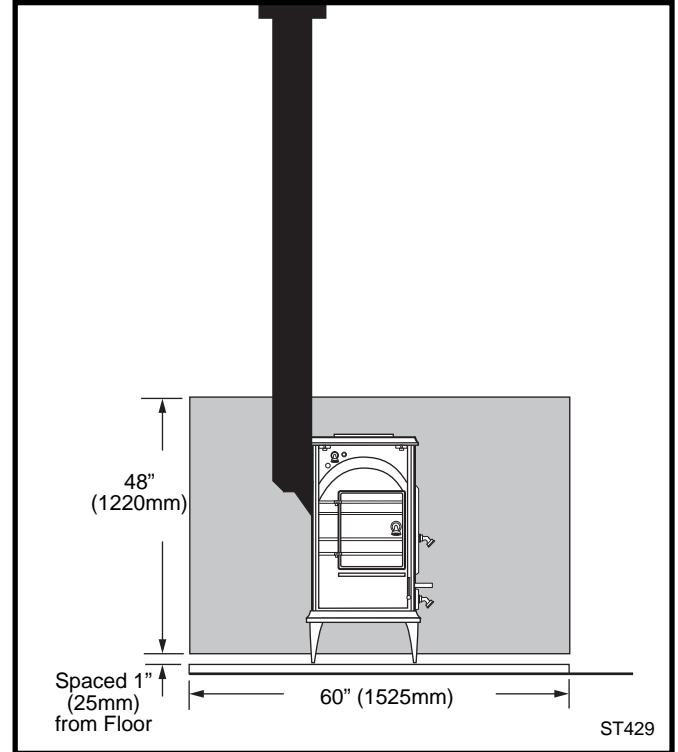

Fig. 17 Sidewall protection.

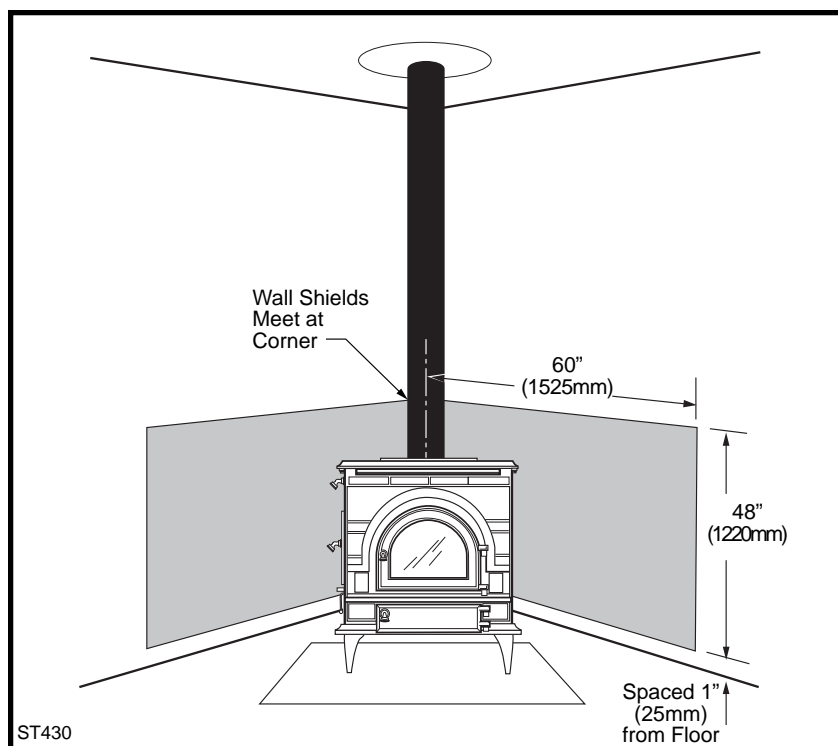

Fig. 18 Corner wall protection.

Assembly

Your convection heater requires some assembly. Follow the directions carefully and refer to the parts diagram at the back of this manual.

Unpack the Parts

Remove all loose parts from the firebox and the ash pan. Check to make sure all the parts are included and intact. You should have received:

- 1 fully assembled heater body, (with catalytic burner installed at the factory)
- 4 legs
- 1 ash pan
- 1 probe thermometer
- 1 ceramic handle assembly
- 1 strip of Interam™ gasket (for the catalytic burner)
- 1 hardware bag, containing the following parts:
 - (3) #10 x 1/2" sheet metal screws, (to attach the chimney connector to the flue collar)
 - (1) 1/8" Allen wrench, (to tighten the door latch)
 - (1) 5/32" Allen wrench, (to tighten the damper handle)
 - (4) washers, (used with the leg bolts to attach legs to the stove)
 - (1) door handle insert holder for storing the ceramic handle assembly when it is not in use.

The four hex-head leg bolts have been installed in the appropriate holes in the bottom of the stove.

If any parts are missing or damaged, immediately notify your Dutchwest dealer for replacements. Do not install your stove without having all necessary parts or by using damaged parts.

*** A Bottom Heat Shield is required in many installations. Refer to the floor protection information found in the Installation Section of this manual.**

Attach the Legs and Heat Shield

Place the stove on its back on a soft surface such as a couple of old blankets. Tilt it carefully; it is heavy. Use 4 x 4 blocking to make it easier to tilt the stove. Protect surrounding flooring with an old blanket or sheet.

The tops of the legs are slotted. Remove each leg bolt from the bottom of the stove and then replace it with a washer from the hardware bag. If you are attaching a bottom heat shield, place a heat shield bracket on each bolt. Place the door handle insert holder on the bolt for the left rear or either front leg. Slide the legs onto the bolts and gently tighten each bolt. (Fig. 19) If you are attaching a bottom heat shield, screw it onto the heat shield brackets.

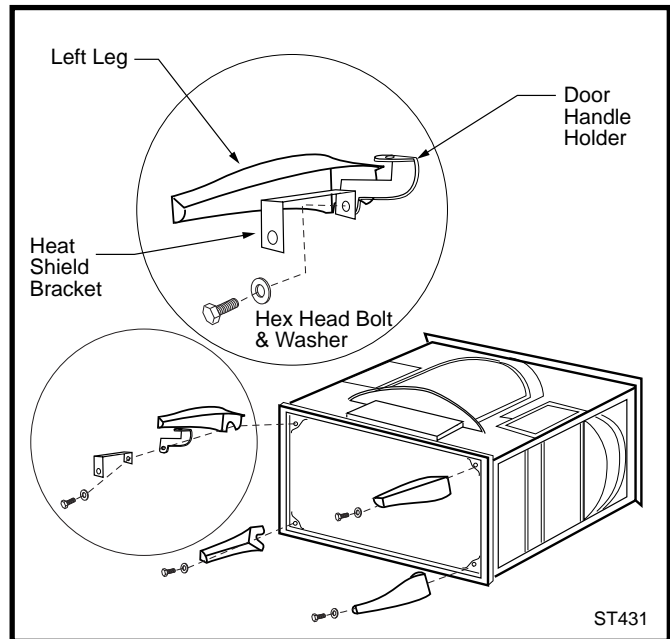

Fig. 19 To attach the legs, remove the bolts from the stove bottom and reassemble with the handle holder, heat shield brackets (if necessary) and washers.

Stand the stove upright and carefully move it to its final position. A trick for moving it easily over smooth flooring is to stand the stove on a piece of scrap carpet, upside down.

If the installation includes an optional rear heat shield, attach it before you begin installing the chimney connector.

Operation

Heater Controls and Features

Air Controls

The Dutchwest Convection Heater has two air controls that regulate the amount of air drawn into the stove. Generally, more air entering the stove allows the fire to burn hotter and faster, while less air decreases heat output while prolonging the overall burn time.

The **Primary Air** control lever is located at the lower front edge of the left side (looking from the front of the stove). (Fig. 20) The lever operates the two air inlet shutters which are on the front of the stove. Opening the inlet shutters provides air for primary combustion.

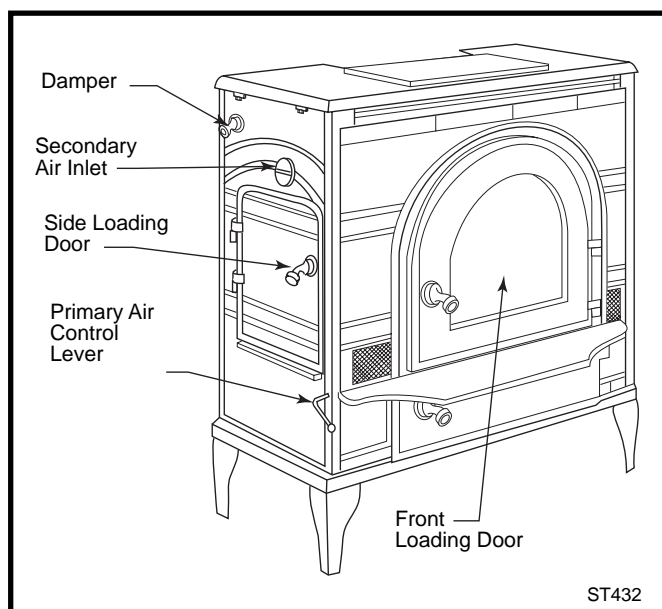

Fig. 20 The heater controls.

To open the shutters, turn the lever counterclockwise. The shutters are all the way open when the lever points toward the front at a "4:30" position. (Fig. 21) To close the shutters, turn the lever clockwise. The shutters are fully closed when the lever points straight down. (Fig. 22)

The secondary air inlet, over the side door, admits air to the catalytic combustor **only**, for high efficiency at high combustor temperatures. Use a gloved hand or the metal tip of the door handle to adjust this inlet. Opening or closing this inlet will not strengthen the fire; generally this inlet should be about one turn open for low fires, and 1½ to 2 turns for medium and high fires.

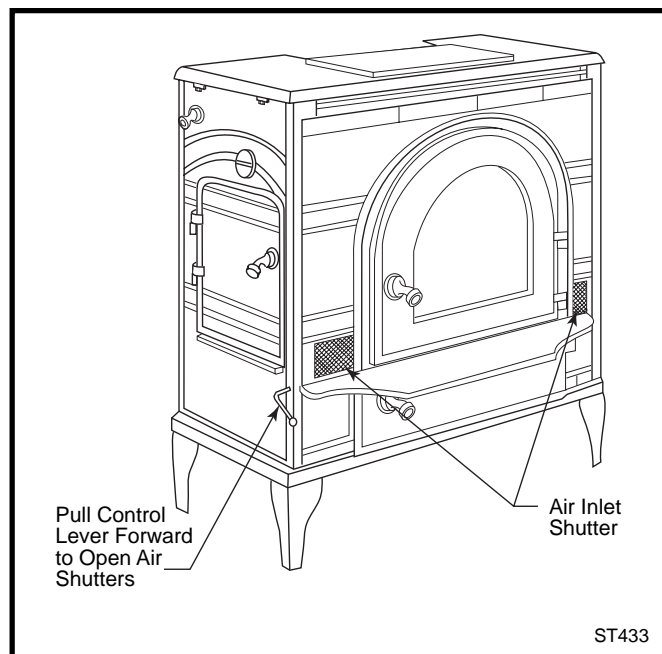

Fig. 21 Opening the primary air supply.

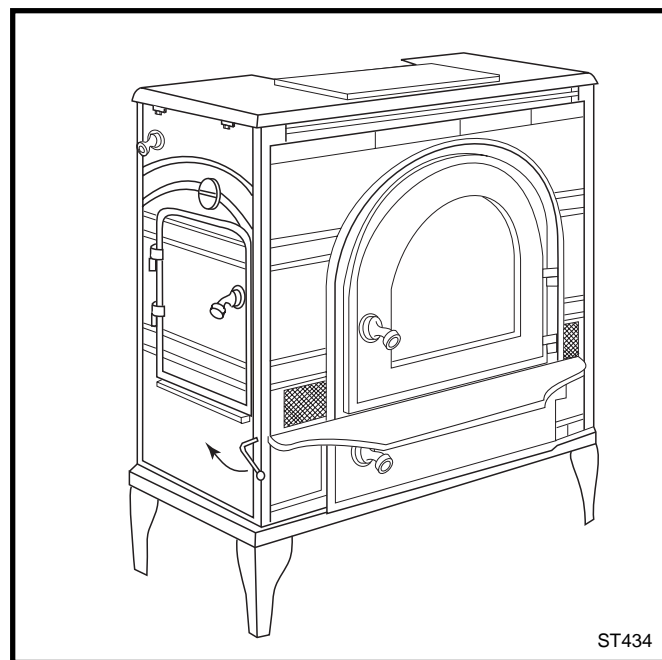

Fig. 22 Closing the primary air supply.

Damper Function

The **Damper** is operated by moving the handle on the upper left side of the stove. (Fig. 23) It has two positions: *OPEN*, to start the fire and load fuel, and *CLOSED*, for greatest efficiency and heat. When the damper is closed, exhaust gases pass through an insulated catalytic burner before flowing into the chimney.

Use the door insert handle to rotate the damper handle. Turn it counterclockwise to open the damper and clockwise to close it. You will feel resistance as the damper mechanism engages into the open (counterclockwise) position.

The stove damper **must** be open when you start a fire, load fuel, or before you open either door for any reason.

Load Doors

A **Side Loading Door** allows the easiest loading of wood logs. The **Front Door** opens for adding an occasional log to the fire. Always be sure to open the stove damper before opening either door.

Successful Wood Burning

Woodburning is often said to be more of an art than a science. You'll easily master the art if you start by using good, dry fuel and by understanding how the stove's air supply system operates.

Burn Only High-Quality Fuel

Your heater is designed to burn natural wood only. Do not burn other fuels. Never burn pressure-treated wood, painted or stained wood, or glossy newsprint.

High efficiencies and low emissions are possible when burning air-dried, seasoned woods as compared to softwoods or freshly cut hardwoods. Avoid burning "green" wood that has not been properly seasoned.

The best hardwood fuels include oak, maple, beech, ash, and hickory that has been split, stacked, and air-dried outside under cover for at least one year. If hardwood is not available, tamarack, yellow pine, white pine, Eastern red cedar, fir, and redwood are softwoods that are commonly burned. They too should be properly dried. The length of the wood should be the same as that specified for your particular stove. Avoid using wood that has been dried more than two years. Often gray in color, this wood burns very quickly, resulting in short burn time and diminished stove performance. If you must burn it, mix it in with greener wood to slow the burn.

Store your firewood under cover to keep it dry. Even for short-term storage, keep wood a safe distance from the heater and keep it clear of the areas around the heater used for refueling and ash removal.

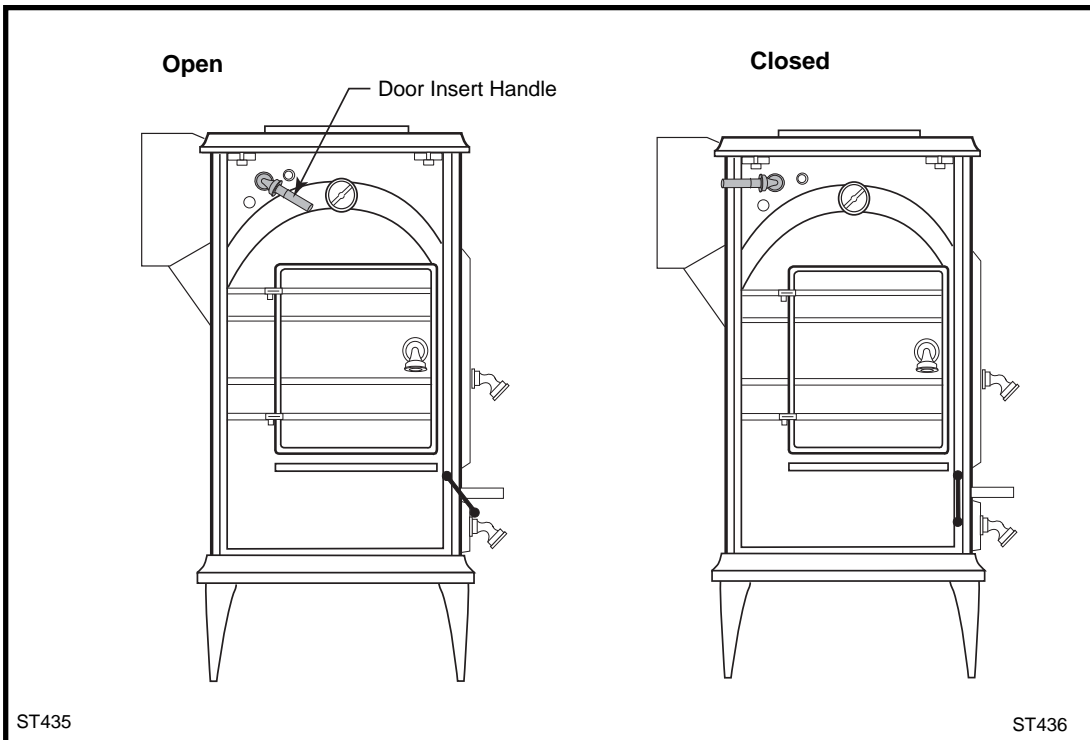

Fig. 23 Damper operating positions.

Use The Air Control Settings That Work Best For You

No single combination of control settings will fit every situation. Each installation will differ depending on the quality of the fuel, the amount of heat desired, and how long you wish the fire to burn.

Control settings also depend on your particular installation's "draft," or the force that moves air from the stove up through the chimney. Draft is affected by such things as the height, type, and location of the chimney, local geography, nearby obstructions, and other factors.

Too much draft may cause excessive temperatures in the stove. On the other hand, too little draft can cause backpuffing into the room and/or the "plugging" of the chimney and catalytic burner.

How do you know if your draft is excessively high or low? Symptoms of too much draft include an uncontrollable burn or a glowing-red part of the stove or chimney connector. A sign of inadequate draft is smoke leaking into the room through the stove or chimney connector joints.

When first using the stove, keep a record of the results you achieve from different control settings. You will find that specific control settings will give you a fixed amount of heat. It may take a week or two to determine the amount of heat and the length of burn you should expect from various control settings.

Notice that the probe thermometer on the stove top tells you the temperature of the catalytic burner *only*; it does not tell you how hot the firebox is. Normal range for the catalyst is 600 to 1400° F (315 to 760° C). The catalyst temperatures are very intense (far more intense than any other part of the stove) but they are also very localized.

You should put a magnetic surface thermometer on the side door. This is the only single-thickness area of the firebox, and it's a handy location since you'll use the side door more than any other.

The normal range of *firebox* temperatures is 400 to 650° F (190 to 330° C). Temperatures below this range can encourage creosote formation in the stovepipe and chimney; higher temperatures can cause stove parts to burn out prematurely. *Always* operate the stove according to firebox temperatures. Besides the air control, you can manage the stove's heat output and burn time by how much wood you load at a time.

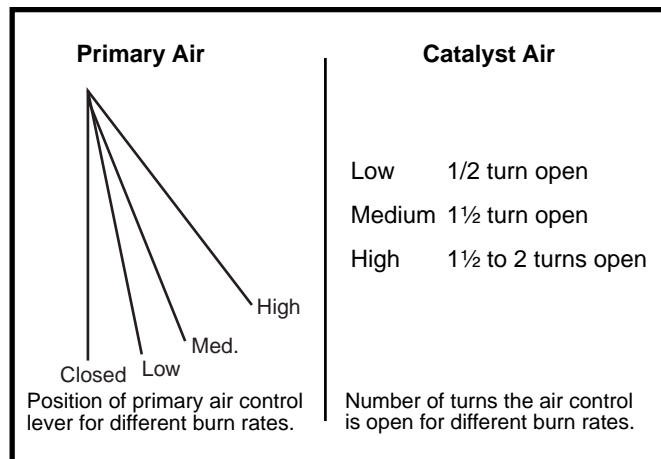

Fig. 24 Primary and Catalyst air settings.

Notice that changes in the weather have a strong effect on chimney draft. Higher outdoor temperatures and lower air pressure both weaken draft; lower temperatures and higher air pressure encourage a stronger draft. An exception to this is in installations with outdoor chimneys; since these lose heat to the outdoors, it takes longer to warm them up initially, and it takes more heat to keep them warm, especially during very low temperatures outdoors.

Most installations do not require a large amount of combustion air, especially if adequate draft is available. Do not attempt to increase the firing rate of your heater by altering the air control adjustment range outlined in these directions.

In some newer homes that are well insulated and weather-tight, poor draft may result from insufficient air in the house. In such instances, an open window near the stove on the windward side of the house (side against which the wind is blowing) will provide the fresh air needed.

Use the air control settings indicated in Figure 24 as a starting point to help determine the best settings for your installation.

DO NOT OPERATE THE STOVE WITH THE ASH DOOR OPEN. OPERATION WITH THE ASH DOOR OPEN CAN CAUSE AN OVERFIRING CONDITION TO OCCUR. OVERFIRING THE STOVE IS DANGEROUS AND CAN RESULT IN PROPERTY DAMAGE, INJURY, OR LOSS OF LIFE.

How to Build and Maintain a Wood Fire

Loading Wood

Your Dutchwest Convection Heater accepts wood from both the front and side. Front loading is useful for kindling a new fire and adding an occasional log, however, we recommend side loading as most convenient when adding several logs at a time. Always be certain that the stove damper is open before opening either door.

WARNING: OPERATE YOUR DUTCHWEST CONVECTION HEATER ONLY WITH THE DOORS FULLY CLOSED EXCEPT WHEN REFUELING.

THIS STOVE IS HOT WHILE IN OPERATION! KEEP CHILDREN, CLOTHING, AND FURNITURE AWAY. CONTACT MAY CAUSE SKIN BURNS.

Break-in Fires

If your stove is new or has new cast iron replacement parts, "season" the new cast iron with a few break-in fires. Follow Steps 1-3 below. Then let the fire burn out. Do not close the damper. Maintain a small, but not smoky, fire by adjusting the primary air control. After the break-in fires, continue with Step 4.

The stove's paint and cement will emit a slight odor as these materials cure during the first few fires. You may wish to provide extra ventilation near the stove by partially opening a door or window when the odor is present.

Lighting the Fire

Step 1. Open the stove damper. Fully open the primary air control and close the secondary (catalyst) air control.

Step 2. Lay some crumpled newspapers in the stove. Place six or eight finger-width size pieces of dry kindling on the paper. On the kindling, lay two or three larger sticks of split dry wood approximately 1-2" (25-50 mm) thick.

DO NOT USE CHEMICALS OR FLUIDS TO START THE FIRE. DO NOT BURN GARBAGE OR FLAMMABLE FLUIDS SUCH AS GASOLINE, NAPHTHA, OR ENGINE OIL.

Also, never use gasoline-type lantern fuel, kerosene, charcoal lighter fluid, or similar liquids to start or "freshen up" a fire in this heater. Keep all such liquids well away from the heater while it is in use.

Step 3. Light the newspaper and close the door. The fire should be well-established within 10-15 minutes. You may gradually build it up by adding a few sticks at a time of a progressively larger size. Continue to build the fire until a live coal bed begins to form.

NOTE: An especially large, outdoor, or cold chimney may need to be "primed," or warmed up, before it will draw sufficiently to start a fire. If this is the case, roll up a couple pieces of newspaper, place them on top of the kindling and toward the back of the stove, light them, and close the doors. This should heat the chimney enough to initiate a draft.

Once the draft is established, open the front door and light the rest of the fuel from the bottom. Do not light the main bed of fuel until the chimney begins drawing. Repeat the procedure as often as necessary if the initial attempt is unsuccessful.

Step 4. After a lively fire has been established, (approx. 30 minutes) close the stove damper.

Step 5. Close the primary air control to a medium low setting. The fire volume will diminish immediately, but the stove will continue to warm up. Maintain control of the fire using the primary air control. Reduce the setting for a smaller fire, increase the setting for a hotter, more intense fire. Refer back to the air control settings chart on pages 19.

Step 6. Open the catalyst air control. Refer back to the air control settings chart on page 19.

DO NOT OVERFIRE THIS HEATER. Overfiring may cause a house fire, or can result in permanent damage to the stove. If a part of the stove or the chimney connector glows, you are overfiring.

Reloading and Reviving the Fire

Open the stove damper and wait at least thirty seconds for the draft to increase. Open the door slowly and add the fuel. Split firewood will fill the firebox more completely than will unsplit wood and will thereby reduce the frequency of reloading.

You may find that the fire intensity will decrease after reloading, particularly if the loading door is open a long time. Stimulate the fire by increasing the primary air supply and leave the stove damper open. Then as soon as the fire is reestablished, close the damper and reduce the air supply to prevent over-firing.

Further suggestions...

- * If the charcoal bed is relatively thick and your fuel is well-seasoned, it is possible to add fresh fuel (smaller pieces first), close the door and damper, and reset the air control within five minutes.
- * When refueling, avoid breaking the charcoal bed into small pieces. Large pieces of charcoal help the fire recover quickly.
- * The glass will remain cleaner if refueling is done when the previous load of fuel has burned down to hot, glowing coals. Use a crumpled piece of dry newspaper to wipe fly ash buildup off of the glass. Do not use liquid cleaning agents of any type on hot glass.

Remove Ashes Frequently

Wear heavy stove gloves when removing ashes. Check the ash compartment before reloading the stove. If the ashes are close to the top, empty the pan. Before replacing the ash pan, clear away any ash that has spilled over the sides and back of the ash pan.

Empty the ash drawer regularly - typically every one to three days. The frequency will vary depending on how hot you run your stove: the hotter the fire, the more wood you burn, and the faster ash will accumulate.

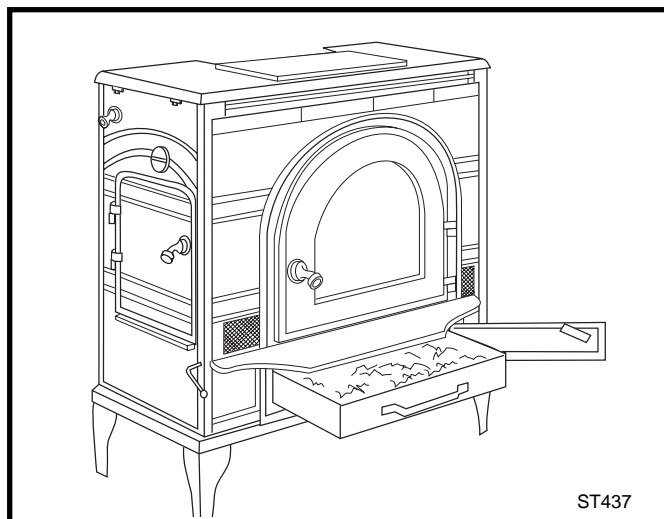
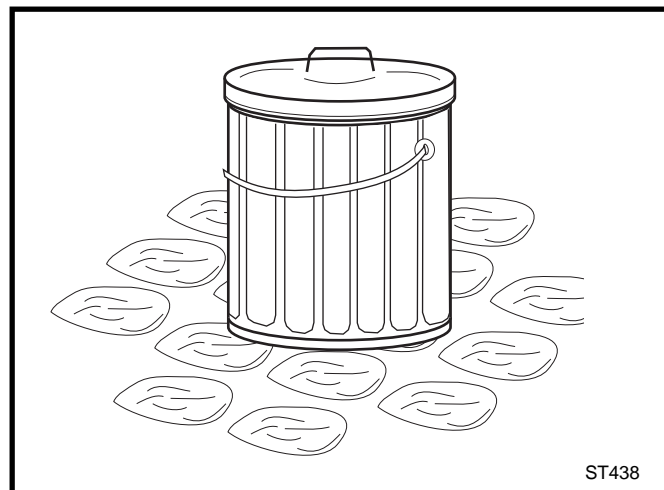

Fig. 25 Hot ashes can be dangerous and must be stored outdoors on a noncombustible surface in a metal container with a tight-fitting lid.

Safe Ash Handling

Ash may contain hot coals and must be treated with extreme care. Ashes should be placed outdoors in a metal container with a tight-fitting lid. The closed container of ashes should be placed on a noncombustible floor or on the ground, well away from all combustible materials, pending final disposal. If the ashes are disposed of by burial in soil or otherwise locally dispersed, keep them in the closed container until all cinders have thoroughly cooled. Wood ash may be used as a garden fertilizer.

CAUTION: Never use a vacuum cleaner to remove ash from the stove; always remove and dispose of the ashes properly.



Maintenance

Keep Your Stove Looking New And Working Its Best

Care of the Cast Iron Surface

An occasional dusting with a dry rag will keep the painted cast iron of your Dutchwest Convection Heater looking new.

If the paint needs retouching, allow the stove to cool completely. Wire-brush areas needing to be painted. Remove non-painted components such as air controls or cover them with masking tape. Touch up the stove with high temperature stove paint available from your local dealer. Apply the paint sparingly. Two light coats are better than one heavy one.

Cleaning the Glass

You will find that most of the carbon deposits on the glass will burn off regularly during hot fires. You can wipe fly ash from the glass when hot using a crumpled piece of dry newspaper. **Never use liquid cleaning agents on hot glass.** If you wish to clean the glass more thoroughly, follow this procedure:

- Be sure the glass is completely cool.
- Use a glass cleaner especially made for this purpose.
- Dry the glass completely.

Adjust the Door Latch

The door latches must close tightly to ensure a good seal between the each door and the stove plates. With time and use, the door latches will require periodic adjustment. Follow this procedure: (Fig. 26)

1. Loosen the small locking nut with an open end wrench.
2. Use the allen wrench (included with the stove) to turn the striker screw clockwise one quarter-turn and close the door to test the engagement. The door latch should engage tightly when closed. Make further adjustments in small increments.
3. When the striker screw is properly adjusted, tighten the small locking nut against the pawl without allowing the striker screw to turn.

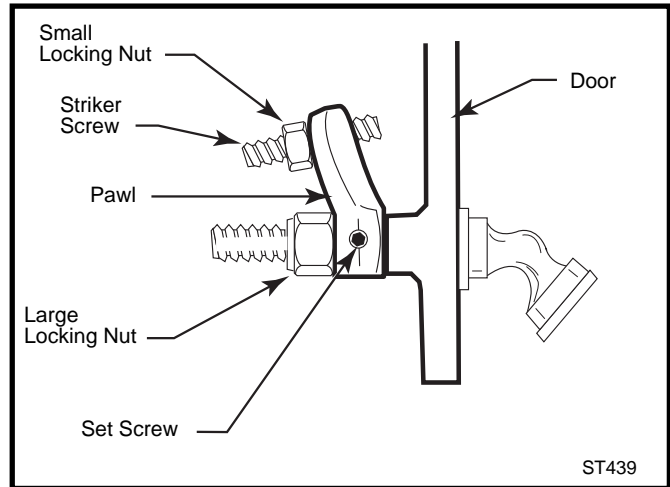

Fig. 26 Door latch adjustment.

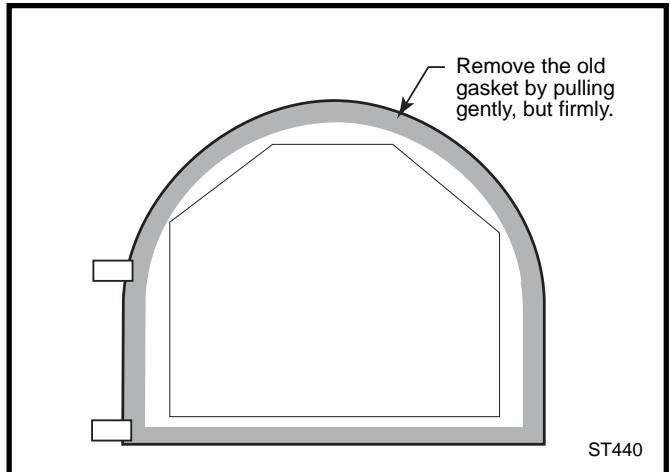

Fig. 27 Door gasket.

Test And Repair the Door Gaskets

Air leaks can be caused by low spots in the door gaskets. To locate such low spots, close each door on a slip of paper and attempt to pull the paper free. If the paper slips out without tearing, the gasket isn't snug enough at that spot.

If the seal cannot be improved by adjusting the door latch, try shimming the gasket. Pack a small quantity of cement or a smaller diameter gasket into the channel beneath the gasket to lift the main gasket and thereby improve its contact with the door frame.

If shimming does not improve the seal, replace the gasket following these steps:

1. Remove the original gasket by grasping an end and pulling firmly.
2. Wearing safety goggles, use a wire brush or the tip of a screwdriver to clean the channel of any remaining cement or bits of gasket.

3. Apply a thin bead of stove cement in the newly-cleaned groove.
4. Lay the gasket into the groove. Wait until you are a couple inches from the end before you cut it.
5. Test the gasket by closing the door on a slip of paper as described above. Adjust the gasket in any areas where an inadequate seal is evident.

All rope-type gasketing used in the Dutchwest Convection Heater is made of fiberglass. The gasketing is 7/16" diameter for front and side doors and the ash door and 3/8" for the top plate. 1/4" gasketing is used behind the glass.

Repair Missing Cement in Seams

The cement in the stove seams may deteriorate over time and fall out in places. Just as with the stove doors, it is necessary to keep the seam seals in good condition. Spot-fix with furnace cement (available from your local dealer) any areas where the cement seal is visibly deteriorated. Allow 24 hours for the new cement to dry after "washing down" seams.

Avoid Damaging the Glass Door Panel

Do not abuse the glass by slamming the door or striking the glass with a log. Never operate your stove if it has damaged or broken glass. If you need to replace the glass, use only replacement glass provided by your local Dutchwest dealer.

Damper Adjustment

With time, you may need to adjust the damper linkage to ensure that the damper plate seals tightly when closed. Test the damper when the stove is cold. When turned into the closed position, the damper should feel "snug" but not too tight. It will become a little tighter as the stove heats up. Use a 7/16" socket wrench with socket extension to adjust the linkage:

1. In an alternating pattern, first loosen and then remove the four bolts that secure the top plate to the sides of the stove.
2. Open the damper.
3. Loosen the adjusting bolt's lock nut. (Fig. 28)
4. Loosen the anchor bolt's lock nut, located on the underside of the damper.
5. Loosen the anchor bolt a turn or two.
6. Tighten the adjusting bolt.
7. Test the damper. Make further adjustments if necessary.
8. When final adjustment has been made, tighten the adjusting bolt lock nut, the anchor bolt, and the anchor bolt lock nut.

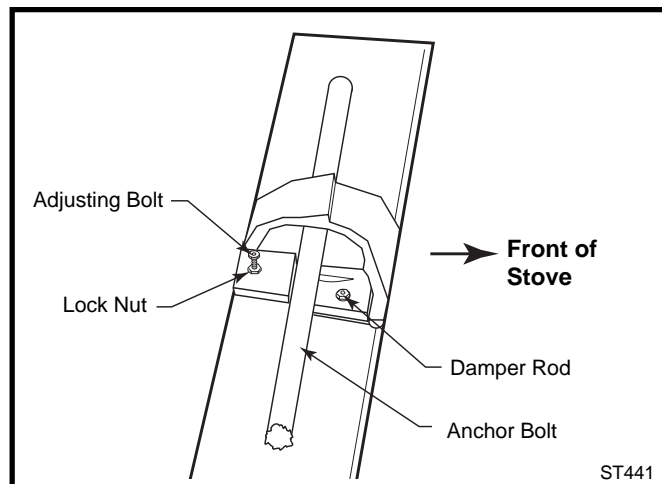

Fig. 28 Damper adjustment.

Primary Air Control Adjustment

A simple spring-loaded tab maintains tension on the primary air control lever. The air control should be loose enough for you to easily set its position by hand, but also snug enough to remain in that position until you change it.

Over time, the air control may tighten or loosen. To adjust the tension on the control, let the stove cool to room temperature. Open the side-loading door and look in toward the inner side of the front panel of the stove. (Fig. 29) Locate the lower hex head bolt (A) on the primary air manifold, just inside the door. Remove the bolt with an open end or box end wrench to gain access to the adjustment screw (B) inside the manifold. Insert a Phillips screwdriver into that hole and turn the screw clockwise to increase tension, counterclockwise to decrease tension. Make adjustments in small increments and test the operation. Replace the hex head bolt when you are done.

Note that the mechanism may tighten slightly as the stove heats up. Your adjustment should leave the air control snug, but not overly tight.

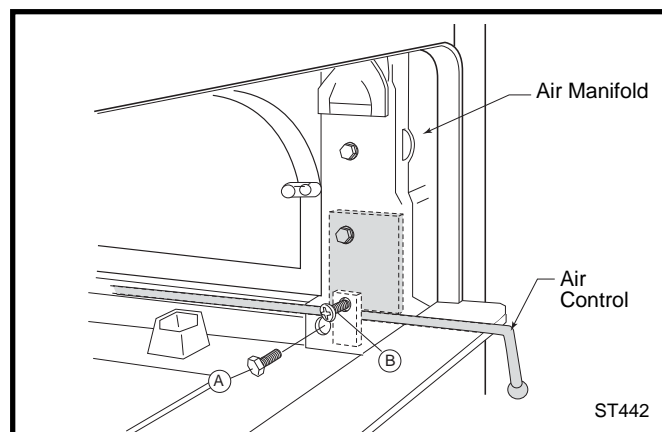

Fig. 29 Primary air control adjustment.

Cleaning the Chimney System

The chimney system is composed of the chimney and the pipe that connects the stove to the chimney. Inspect the chimney and chimney connector at least twice monthly, and clean if necessary.

When you first begin using the stove, check daily for creosote — a substance that can look like either thick tar or black, crisp flakes. Experience will show how often you need to clean to be safe. The frequency may even vary during the year. In the colder months when the hottest fires producing the least creosote are burned, you may need to clean only every couple of months. During the warmer months when creosote is more likely to result from cooler-burning fires, weekly cleaning may be necessary.

At the very least, inspect the chimney connector and chimney at least once every two months during the heating season to determine if a buildup of creosote or soot has occurred. If a significant layer of creosote has accumulated (1/8" [3 mm] or more), or if soot has accumulated, either should be removed to reduce the risk of a chimney fire. Failure to keep the chimney and connector system clean can result in a serious chimney fire.

The conditions for a chimney fire develop as follows: When wood is burned slowly, it produces tar and other organic vapors which combine with expelled moisture to form creosote. The creosote vapors condense in the relatively cool chimney flue of a slow-burning fire. As a result, creosote residue accumulates on the flue lining. Creosote is flammable and, when ignited, makes an extremely hot fire within the flue system which can damage the chimney and overheat adjacent combustible material.

To reduce the amount of creosote that may form, remember to provide adequate air for combustion and to strive for small, intense fires rather than large, smoldering ones.

You can never be too safe. Contact your local fire authority for information on what to do in the event of a chimney fire, and have a clearly understood plan on how to handle one.

Inspect Regularly, Clean As Required

Inspect the chimney and chimney connector twice monthly and clean if necessary. Let the stove cool completely before you inspect the chimney. Use a flashlight and mirror to sight up the flue through the chimney clean-out door or chimney connector inspection tee. If no inspection access is available, disconnect the pipe from the stove.

Clean the chimney using a specially designed chimney cleaning brush, the same size and shape as the flue liner, attached to flexible fiberglass rods designed for this purpose. Run the brush up and down the liner so that any deposits fall to the bottom of the chimney where they can be removed through the clean-out door.

Clean the chimney connector by disconnecting the sections, taking them outside, and removing any deposits with a stiff wire brush. You can use a chimney brush of correct size to clean chimney connector pipe. Reinstall the connector sections after cleaning, being sure to secure the individual sections with three sheet metal screws per section.

If you are unable to inspect and/or clean the chimney system yourself, contact your local Dutchwest dealer or hire a qualified chimney sweep in your area to do the job.

Maintenance Schedule

THE STOVE:

DAILY:

- Ashes should be removed before they reach the top of the ash pan. Check accumulation at least once a day.
- Keep the area around the stove clear of any combustible materials such as wood, furniture or clothing.

TWO MONTHS:

- Check door handle to be sure it is working properly. Gasketing becomes compressed after a period of time. Adjust handle tightness if necessary.
- Check leg bolts and heat shield screws; tighten if necessary.

Annual Spring Cleaning

- Check gasketing for wear, and replace if necessary.
- Remove ashes from the ash pan and replace with a moisture absorbing material (such as kitty litter) to keep the interior of the stove dry.
- Inspect and clean the refractory package and catalyst.
- Clean the dust from the inner sides of bottom, rear or pipe heat shields if your stove is equipped with them. Clean surfaces are better heat reflectors than dirty surfaces.
- Touch up the black paint.

The Chimney Connector

TWO WEEKS:

- Inspect the chimney connector and chimney. Clean if necessary.

TWO MONTHS:

- Inspect the chimney and chimney connector. Pay particular attention to the horizontal runs of chimney connector, and the elbows. Clean the system if necessary.

Yearly Spring Cleaning

- Disassemble the chimney connector and take it outdoors for inspection and cleaning. Replace weak sections of connector.
- Inspect the chimney for signs of deterioration. Repairs to a masonry chimney should be made by a professional mason. Replace damaged sections of prefabricated chimney. Your local Dutchwest dealer or a chimney sweep can help determine when replacement is necessary.
- Thoroughly clean the chimney.

Care Of The Catalytic Combustor

This wood heater contains a catalytic combustor, which needs regular inspection and periodic replacement for proper operation. It is against the law in the United States to operate this wood heater in a manner inconsistent with operating instructions in this manual, or if the catalytic element is deactivated or removed.

Under normal operating conditions, the catalytic combustor should remain active for two to six years (depending on the amount of wood burned). However, it is important to monitor the combustor periodically to ensure that it is functioning properly, as well as to determine when it needs to be replaced. A non-functioning combustor will result in a loss of heating efficiency, and an increase in creosote and emissions.

The combustor should be visually inspected "in place" for fly ash accumulation and physical damage three times per year. Actual removal of the combustor is not recommended unless a more detailed inspection is warranted because of diminished performance as outlined below.

The refractory package housing the catalytic combustor should be inspected annually for a build-up of fly ash and cleaned if necessary. This may be done during examination of the catalytic combustor.

When To Suspect A Combustor Problem

There are two ways to evaluate the performance of your stove's combustor.

The first is to monitor the temperatures on the probe thermometer. A properly-functioning combustor should operate in the range of 800-1200°F. (430-650°C.). Combustor temperatures consistently less than 800°F. (430°C.) merit a closer examination of the combustor.

The second performance test is to observe the amount of smoke leaving the chimney — both when the combustor has achieved "light-off" and when it has not. Follow this simple two-step procedure:

- With a fire in the stove and the combustor properly activated by the closing of the stove damper to route smoke through it as described in the Operation Section, go outside and observe the smoke leaving the chimney.
- Then, open the stove damper and once again observe the smoke leaving the chimney.

Significantly more smoke should be observed after the second step when the stove damper is open and exhaust is not routed through the combustor. Be careful not to confuse smoke with steam from wet wood. Unlike smoke, steam disappears very quickly in air.

If either of these tests indicates a problem, consider other possible factors as well.

Assess Your Present Operating Conditions

In Spring or Fall, draft strength is less than in the middle of winter, and a related change in stove performance may result. Small hot fires are a good solution to sluggish performance under these conditions.

Burning "green" (insufficiently seasoned) wood will result in poorer performance than when burning properly seasoned fuel. Was your fuel supply good and dry to start with, or has it changed? You may have to run your stove hotter (more air) to achieve good performance if you are burning green or wet wood. Also, any changes in operating routine should be considered at this time as a possible reason for changed performance.

Once you have ruled out any other possible causes for a decline in performance, you may proceed with an inspection of the catalyst.

Remove and Inspect the Combustor

- Wear safety glasses, a dust mask, and gloves.
- Remove the four bolts that secure the stove top plate. There are two each on both the left and the right side, just under the top plate overhang. With the bolts removed, lift the top.

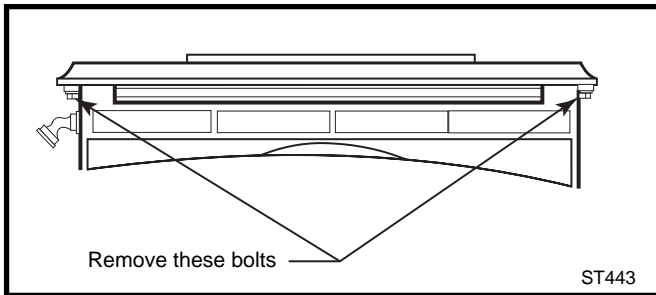

Fig. 30 Remove four bolts securing stove top plate.

The combustor is located beneath the removable refractory package.

- Carefully remove the refractory package. It is extremely delicate; handle it as little as possible.

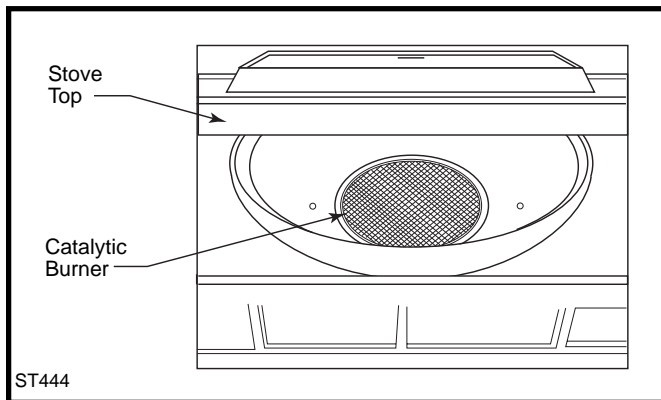

Fig. 31 Remove refractory package with care.

- For a visual inspection for blockage that can be performed without removing the combustor, have an assistant shine a bright flashlight beam up through the combustor from inside the stove's firebox.
- If combustor removal is necessary for cleaning or closer inspection, lift it gently out of its chamber. You may have to work it back and forth carefully to remove it. Check the combustor and the bottom of the refractory chamber for a build-up of fly ash, and remove any ash by gently blowing air through the combustor. Do not brush the surface, as this could damage the element.

- Inspect the combustor, referring to the information in the "Catalytic Combustor Appendix" on Page 27 for information on what to look for. Although small hairline cracks will not affect performance, the combustor should be essentially intact. If the combustor is broken in pieces or has sections missing, it should be replaced. Call your local Dutchwest dealer for a replacement combustor, item #CB56. Consult the warranty section at the back of this manual for further information on catalytic combustor replacement.

- If the combustor is in good condition and clean, re-install it. Be sure first to carefully wrap a new Interam gasket (an extra was provided with your stove) around its perimeter before replacement. Insert the gasketed combustor gently back into position, and replace the refractory package.

- Before replacing the stove top, check the damper. If the gasket is intact, but the damper isn't locking tightly, adjustment should be made. Also check the gasket that seals the top plate.

- Gasket should be replaced only if damaged or missing. The top plate uses a 3/8" gasket and the damper is sealed with a 3/8" gasket. The procedure for removing the old gasket and installing the new is the same as that described for door gaskets on Page 19.

- Replace the stove top, and tighten the four top plate bolts that secure it. Be sure that the top plate seats properly before tightening, and tighten the bolts alternately as you would tighten the bolts that secure a car tire.

Watch for Better Results

Finish up by cleaning the chimney connector. Then, use the stove in your typical manner for two weeks and note the stove's performance, taking special note of the performance tests described above.

If a problem persists, contact your Dutchwest dealer for further advice about your particular situation.

Catalytic Combustor

In any chemical reaction, including the combustion process, there are certain conditions which must be met before the reaction can take place. For example, a reaction may require a certain temperature, or a certain concentration of the reactants (the combustion gases and oxygen), or a certain amount of time. Catalysts, though not changed themselves during the reaction, have the ability to act at a molecular level to change these requirements. In the secondary combustion chamber of the Dutchwest Convection Heaters, the catalyst reduces the temperature at which secondary combustion can start from the 1000 - 1200° F. (540 - 650° C) range to the 500 - 600° F. (260 - 315° C) range, increasing efficiency, and reducing creosote and emissions.

Though it is advantageous, the catalytic reaction does have some limitations of its own. Primary among these is that the reactants (the gases) come into close physical contact with the catalyst itself.

To ensure the necessary contact, the catalytic element in your Dutchwest Convection Heater is composed of a ceramic base in the shape of a honeycomb. On each of the honeycomb's many surfaces a coating of the catalyst (usually a noble metal such as platinum or palladium) is applied. The large surface area exposed in this configuration ensures that the combustion gases have the greatest opportunity to come in contact with the catalyst.

Loss of catalytic activity will be apparent in several ways. First you may notice an increase in fuel consumption. Second, there will be a visible increase in the rate at which creosote builds up in your chimney connector system. You may also notice a heavy discharge of smoke from the chimney. There are a number of catalytic problems which can cause loss of activity:

Blockage

While the honeycomb pattern ensures good contact, it also increases the resistance to flow of the combustion gases, and, because of the many surfaces, provides more places for creosote and fly ash to deposit. It is important to follow the operating instructions in order to minimize these deposits, and to periodically inspect your catalyst for signs of blockage.

Masking and Poisoning

While the catalyst itself does not enter into the combustion process, it is possible for certain elements, such as lead and sulfur, to attach to the active sites on the surface of the honeycomb. Though the catalyst is still there, it is covered, or masked, by the contaminant, and cannot function. To avoid this situation, it is important not to burn anything in your Dutchwest Convection Heater that is a source of these contaminants. Particularly avoid painted or treated wood, coal, household trash, colored papers, metal foils, or plastics. Chemical chimney cleaners may also contain harmful elements. The safest approach is to burn only untreated, natural wood.

Flame Impingement

The catalytic element is not designed for exposure to direct flame. If you continually overfire your Dutchwest Convection Heater, the chemistry of the catalyst coating may be altered, inhibiting the combustion process.

Thermal degradation of the ceramic base may also occur, causing the element to disintegrate. Stay within the recommended guidelines of the Operation section.

Mechanical Damage

If the element is mishandled, damage may occur. Always treat the element carefully. Remember the catalyst is made of a ceramic material; treat it as you would fine china. Hairline cracks will not affect the performance of the catalyst, as long as the steel sleeve holds the element in the proper position.

Peeling

Peeling of the surface coat may occur if the catalytic element is frequently subjected to excessive temperatures. Follow the operating instructions carefully to avoid this type of damage.

Every Dutchwest product is equipped with either a Corning "Long-Life"[®] or a Technical Glass Products "Honeycomb"[®]. The products are equivalent. If for any reason you must ship your catalytic element, remember its fragile nature. Place the element in a plastic bag, and package it with a generous amount of shock absorbing material.

Draft Management

Your stove is only one part of a system that includes the chimney, the operator, the fuel, and the home. The other parts of the system will affect how well the stove works. When there is a good match between all the parts, the system works well.

Wood stove operation depends on natural (unforced) draft. Natural draft occurs when exhaust gas is hotter (and therefore lighter) than the outdoor air at the top of the chimney. The greater the temperature difference, the stronger the draft. As the hot exhaust gas rises out of the chimney, it generates suction that draws air into the stove for combustion. A slow, lazy fire when the stove's air inlets are fully open indicates a weak draft. A brisk fire, supported only by air entering the stove through the air inlets, indicates a good draft. The inlets are passive; they regulate how much air *can* enter the stove, but they don't force air into it.

The efficiency of a modern woodburning appliance, (in which the amount of air available for combustion is regulated), depends on the chimney to keep exhaust gases warm all the way outdoors. The characteristics of your chimney - whether it is steel or masonry, interior or exterior, matched or mismatched to the stove outlet, - determine how quickly it will warm up and how well it will sustain the optimum temperatures necessary to maintain strong draft and efficient combustion. Here follows a description of various flue system characteristics and the related effects on stove performance.

Masonry Chimney

Although masonry is the traditional material used for chimney construction, it can have distinct performance disadvantages when used to vent a controlled-combustion woodstove. Masonry forms an effective 'heat sink' - that is, it absorbs and holds heat for long periods of time. The large mass, however, may take a long time to become hot enough to sustain a strong draft. The larger the chimney (in total mass), the longer it will take to warm up. Cold masonry will actually cool exhaust gases enough to diminish draft strength. This problem is worse if the chimney is located outside the home or if the chimney flue has a cross-sectional volume much larger than the stove outlet.

Steel Chimney

Most factory-made 'Class A' steel chimneys have a layer of insulation around the inner flue. This insulation keeps the smoke warm and protects the surrounding structure from the high flue temperatures. Because the insulation is less dense than masonry, the inner steel liner warms up more quickly than a masonry chimney; this makes the steel chimney support a good draft more quickly than masonry does. Steel chimneys are not as attractive as masonry, but they are very durable and generally outperform masonry.

Indoor/ Outdoor Location

Because the chimney's function is to keep the smoke warm, it is best to locate it inside the house. This location uses the house as insulation for the flue and allows some radiant heat release from the flue into the home. Since an interior chimney doesn't continuously lose its heat to the outdoors, less heat from the stove is required to get it warm and keep it warm.

Flue Sizing

The flue size for a controlled-combustion appliance should be based on the cross-sectional volume of the stove flue outlet. In this case, more is definitely not better. Hot gases lose heat through expansion; if a stove with a six-inch flue collar (28 square inch area) is vented into a 10" x 10" flue, the gases will expand to over three times their original volume. As gases cool with expansion, draft strength decreases. If an oversized flue is also outside the house, the heat it absorbs will be conducted to the outdoor air and the flue will remain relatively cool.

It is common for a masonry flue to be oversized for the stove. Such a chimney can take quite a while to warm up and the stove performance will likely be disappointing. The best solution to an oversize flue problem is the installation of an insulated steel chimney liner of the same diameter as the appliance flue outlet. The liner keeps the exhaust gas warm and the result is a stronger draft. An uninsulated liner is a second choice - although the liner will keep the exhaust restricted to its original volume, the air around the liner will require time and heat energy to warm up.

Check your local codes. You may be required to install a flue liner in any oversize or masonry flue.

Pipe & Chimney Layout

Every bend in the flue will act as a brake on the exhaust as it flows from the firebox to the chimney cap. The ideal pipe and chimney layout is straight up from the stove through a completely straight chimney. Use this layout if at all possible as it will promote optimum stove performance and simplify maintenance.

If the stovepipe must elbow to enter a chimney, locate the elbow about midway between the stove top and the chimney thimble. This configuration lets the smoke speed up before it must turn, keeps some pipe in the room for heat transfer, and allows long-term flexibility for installing a different appliance without relocating the thimble.

There should be no more than eight feet of single-wall stove pipe between the stove and a chimney. Longer runs can cool the smoke enough to cause draft and creosote problems. Use double-wall stove pipe for longer runs.

Single Venting

Your stove requires a dedicated flue. Do not connect the stove to a flue used by any other appliance. Chimney draft is a natural form of energy and follows the path of least resistance. If the stove is vented to a flue that also serves an open fireplace or another appliance, the draft will also pull air in through those avenues. The additional air flow will lower flue temperatures, reduce draft strength and promote creosote development; overall stove performance will suffer. The effect is similar to that of a vacuum cleaner with a hole in the hose. In some extreme instances, the other appliance can even impose a negative draft and result in a dangerous draft reversal.

Fuel

Even the best stove installation will not perform well with poor fuel. If available, always use hardwood that has been air-dried ("seasoned") 12-18 months. Softwood burns more rapidly than hardwood and has a high pitch content conducive to creosote production. Decayed wood of any type has little heat value and should not be used.

All unseasoned ('green') wood has a high moisture content. Much of its heat value will be used to evaporate moisture before the wood can burn. This significantly reduces not only the amount of energy available to warm your home, but also the intensity of the fire and temperature of the exhaust gas. Incomplete combustion and cool flue temperatures promote creosote formation and weak draft.

You can judge the moisture content of wood by its appearance and weight or use a commercially available moisture meter for an exact measurement. Unseasoned wood will be a third heavier than dry wood. Also, look for cracks ("checking") in the ends of the log that result from contraction as the wood dries. The longer and wider the cracks are, the dryer the wood is.

Purchase your fuel from a reputable dealer.

Creosote

Creosote is a by-product of low-temperature stove operation, weak draft, or both. It is a tar that results when unburned gases condense inside the flue system at temperatures below 290° F. Creosote is volatile and can generate a chimney fire. All of the installation characteristics that adversely affect chimney draft also promote creosote condensation. Consequently, you can minimize creosote accumulation with an effective chimney design and the use of operational techniques that encourage good draft and complete combustion. Inspect your chimney frequently and clean it whenever accumulation exceeds 1/4".

Backpuffing

Backpuffing is a condition that results when the draft is too weak to pull flue gases out of the chimney system as

fast as the fire generates them. Volatile gases build up within the firebox until reaching a density and temperature at which they ignite. With this ignition, you may hear a muffled popping sound and see a bit of smoke forced out of the stove.

This condition is most likely to occur in the Spring or Fall when moderate outdoor temperatures and low intensity fires produce weak draft. If your stove back-puffs, open up the damper to let the smoke rise to the flue more quickly. Also, open the air inlets to induce a livelier fire and speed airflow through the stove. Avoid large loads of firewood at one time. You should always see lively, dancing flames in the firebox; a lazy, smoky fire is inefficient and will promote draft problems.

Draft Testing

An easy way to determine whether your chimney draft is strong enough is to close the stove damper, wait a few minutes to let the airflow stabilize, and then test whether you can vary the strength of the fire by swinging the air control open and closed. Results here are not instant; you may need to wait a few minutes for a change in the air control setting to have an effect on the fire. If there is no change, the draft is not yet strong enough to let you close the damper. You will need to open it for a while longer and manage the fire with the air inlet until the draft strengthens. Keep a record of your operating habits and relate them to their effects on the stove's function. You'll be rewarded with safe and efficient performance.

Negative Pressure

Good draft also depends on a sufficient supply of air to the stove. The chimney can't pull in more air than is available to it. Sluggish draft can be caused by a house that is tight enough to prevent the ready flow of air to the stove, or by competition between the stove and other appliances that vent indoor air to the outside; i.e., exhaust fans for range hoods, clothes dryers, bathroom fans, etc. If the chimney draws well when all such equipment is turned off (or sealed, in the case of fireplaces and/or other stoves), you need to be attentive in timing the use of the other appliances. If you need to crack a nearby window or door to enable the chimney to pull well, you should install an outside-air intake to bring combustion air into the room.

Conclusion

Woodburning is more an art than a science. Art includes technique; and since installations, homes, and fuel vary, the stove operator must also vary technique, (mostly timing), to achieve satisfying results. Over time, you will become familiar with the features of your particular installation; you will be able to identify cause and effect in a variety of seasonal circumstances, and adapt your operating habits to changing conditions.

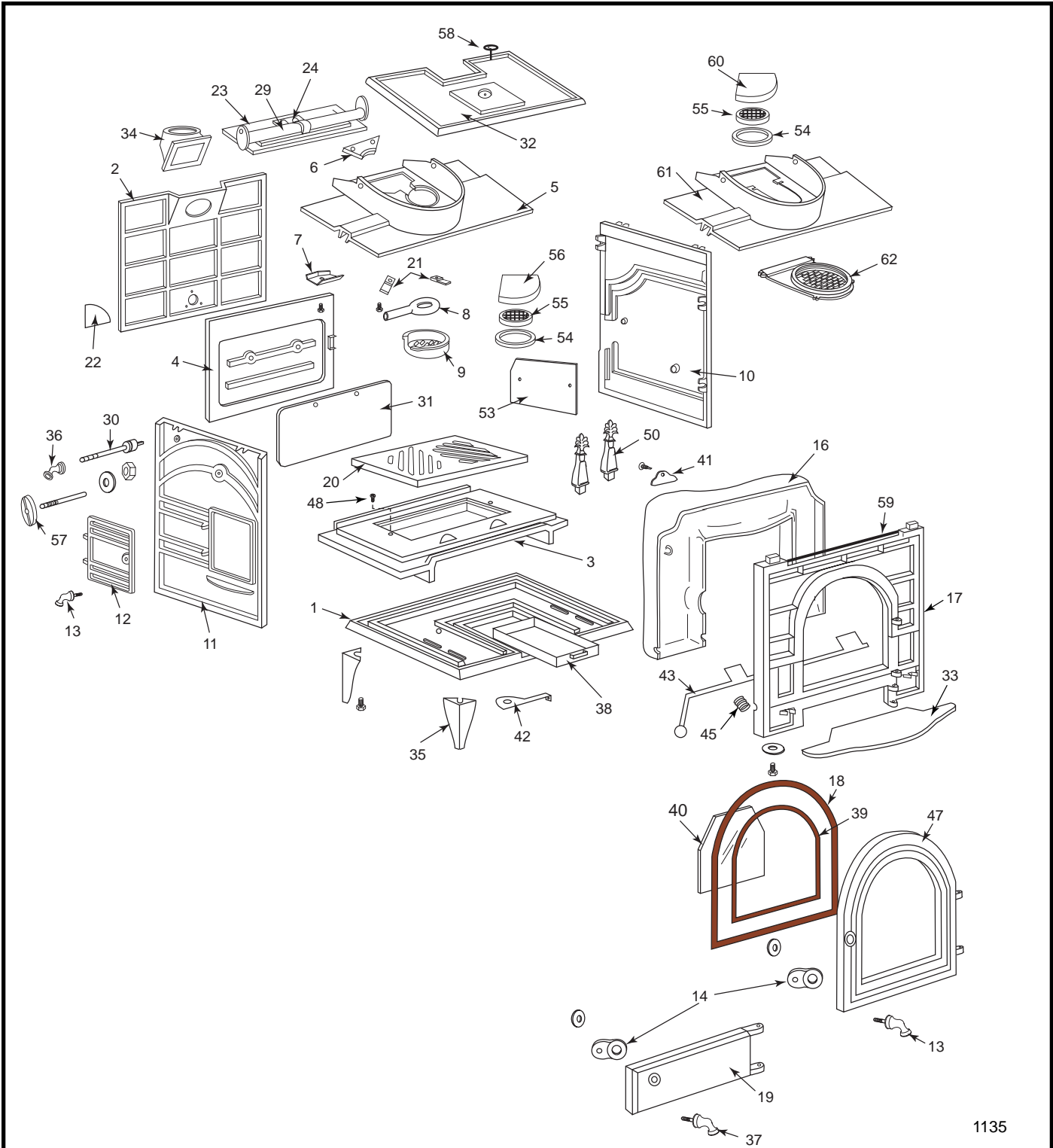

1135

Vermont Castings, Majestic Products reserves the right to make changes in design, materials, specifications, prices and discontinue colors and products at any time, without notice.

Dutchwest Convection Heater

Models 2460, 2461, 2462

Dutchwest Convection Heater

Models 2460, 2461, 2462 (continued)

Item/Description	2460	2461	2462
1. Bottom	7000958	7000978	7000979
2. Outer Back	7001144	7001231	7001234
3. Inner Bottom	7001136	7001116	7001149
4. Inner Back (After 9/97 No Outside Air Slot) (Before 9/97 Slot for Outside Air)	7001130 7001173	7001230 7001174	7001233 700084
5. Inner Top	7001112	7001119	(See Item #61)
Inner Top Ass'y (Inner Top, Web, Gasket, Tabs & Bolts)	0000003	0000004	0000016
Inner Top Ass'y (Inner Top, Web, All Hardware, Baffle, Damper, All Gaskets)	--	7001171	--
6. Inner Top Web	7001110	7001110	7000110 (to 7/97)
7. Inner Top Channel Cap	7000961	7000974	7000987
8. Air Distributor	7000952	7000952	7000952
9. Baffle	7000953	7000953	--
10. Right Side (After 7/97 no outside air)	7001229	7001229	7001232
11. Left Side	7001120	7001120	7001150
12. Side Door	7001121	7001121	7001151
13. Load Door Handle (2)	5004273	5004273	5004273
14. Door Pawl (3)	5004025	5004025	5004025
16. Primary Air Manifold	7001137	7001122	7001152
17. Front	7001139	7001124	7001154
18. Gasket for Front Door	7000910	7000910	7000910
19. Ashdoor	7001141	7001126	7001156
20. Grate	7001118	7001118	7001148
21. Retainer Tab for Web (2)	1601488	1601488	1601488
22. Fan Plate	7000037	7000037	7000037
23. Damper	7000954	7000954	7000954
24. Damper Adjuster	7000950	7000950	7000950
28. Damper Tab (2)	1601488	1601488	1601488
29. Damper Crank	7000951	7000951	7000951
30. Damper Operating Rod	7001160	7001160	7001160
31. Grate Back	7001166	7001166	7001178
32. Top	7000960	7000972	7000985
33. Hearth	7001142	7001127	7001157
34. Flue Collar	7000969	7000969	1304280
35. Leg	7000016	7000016	7000016
36. Damper Handle Stub	5004267	5004267	5004267
37. Ash Door Handle	5004271	5004271	5004271
38. Ash Pan	7000G79	7000G69	7000G89
39. Gasket for Glass	1203591	1203591	1203591
40. Glass	7001146	7001132	7001161
41. Manifold Cap (2)	7001163	7001164	7001165
42. Holder for Door Handle Insert	1600600	1600600	1600600
43. Primary Air Control	7001143	7001129	7001158
44. Damper Tab for Primary Control	1601488	1601488	1601488
45. Spring for Primary Control	1201846	1201846	1201846
47. Front Door	7001140	7001125	7001155
48. Inner Bottom Screw, 1/4-20 x 3/4"	1201394	1201394	1201394
50. Andiron (2)	7001117	7001117	7001117
53. Side Wear Plate	7001198	7001198	7001199
54. Interam Gasket	1203540	1203540	1203545
55. Catalytic Combustor	700B566	700B566	700B566
56. Refractory	1602515	1602515	1602515 (to 7/97)
57. Combustor Air Inlet	7001128	7001128	7001128
58. Probe Thermometer	7000948	7000948	7000948
59. Brass Bar	7001179	7001180	7001181
60. Refractory Package ¹ (as of 7/97)	--	--	1602514
61. Inner Top ¹	--	--	7001226
62. Inner Top Insert/Baffle Combination as of 1/97 ²	--	--	7001225

¹ On Extra-Large units built after August 1997, Refractory differs from Small & Large units.

² On Extra-Large units built after August 1997, Inner Top and Insert differ from pre-August 1997 units.

Warranty

Limited Three Year Warranty

The Vermont Castings Majestic Products Company warrants that this Dutchwest Convection Heater will be free of defects in material and workmanship for a period of three years from the date you receive it, except that the glass door panel and gasketing shall be warranted for one year as described below. There is a separate warranty for the catalytic combustor.

The Vermont Castings Majestic Products Company will repair or replace, at its option, any part found to be defective upon inspection by a Vermont Castings Majestic Products Authorized Dealer. The customer must return the defective part or the stove, with shipping prepaid, to the Authorized Dealer or pay for any Authorized Dealer in-home travel fees or service charges for in-home repair work. It is the dealer's option whether the repair work will be done in the customer's home or in the dealer's shop. If, upon inspection, the damage is found to be the fault of the manufacturer, repairs will be authorized at no charge to the customer for parts and/or labor.

Any Dutchwest Convection Heater or part thereof that is repaired or replaced during the limited warranty period will be warranted for a period not to exceed the remaining term of the original limited warranty or six (6) months, whichever is longer.

Limited One Year Warranty

The glass panel and gasketing of the Dutchwest Convection Heater are warranted to be free of defects in material and workmanship for a period of one year from the date you receive it. Any of these items found to be defective will be repaired or replaced at no charge, upon the return of said part to a Vermont Castings Majestic Products Authorized Dealer with postage prepaid.

Limited Catalyst Warranty

The catalyst will be warranted for a six year period as follows: If the original catalyst or a replacement catalyst proves defective or ceases to maintain 70% of its particulate emission reduction activity (as measured by an approved testing procedure) within 24 months from the date the Dutchwest Convection Heater is received, the catalyst itself will be replaced free.

From 25 - 72 months a pro-rated credit will be allowed against a replacement catalyst and the cost of labor necessary for its installation at the time of replacement.

There is a third year coverage at 100% for combustor failure due to thermal degradation of the substrate (crumbling of ceramic material). The customer must pay for any in-home travel fees, service charges, or transportation costs for returning the Dutchwest Convection Heater to the Authorized Dealer.

Amount of Time Since Purchase	Credit Towards Replacement Cost
0 - 24 months	100%
25 - 36 months	50 %
37 - 48 months	30%
49 - 60 months	20%
61 - 72 months	10%

Any replacement catalyst will be warranted under the terms of the catalyst warranty for the remaining term of the original warranty. The purchaser must provide the following information in order to receive a replacement catalyst under the terms of this limited warranty:

1. Name, address and telephone number.
2. Proof of original purchase date.
3. Date of failure of catalyst.
4. Any relevant information or circumstances regarding determination of failure.
5. In addition, the owner must return the failed catalyst.

Exclusions & Limitations

1. This warranty is transferable; however, proof of original purchase is required.
2. This warranty does not cover misuse of the Dutchwest Convection Heater as described in the Owner's Guide, nor does it cover a Dutchwest Convection Heater that has been modified unless authorized by a Vermont Castings Majestic Products representative in writing.
3. This warranty does not cover a stove repaired by someone other than a Vermont Castings Majestic Products Authorized Dealer.
4. Damage to the unit while in transit is not covered by this warranty but is subject to claim against the common carrier. Contact the Authorized Dealer from whom you purchased your Dutchwest Convection Heater. (Do not operate the Convection Heater as this may negate the ability to process the claim with the carrier.)
5. Claims are not valid where the installation does not conform to local building and fire codes or, in their absence, to the recommendations in the Owner's Guide.
6. The Vermont Castings Majestic Products Company shall have no obligation to enhance or update any unit once manufactured.

IN NO EVENT SHALL THE VERMONT CASTINGS MAJESTIC PRODUCTS COMPANY BE LIABLE FOR INCIDENTAL AND CONSEQUENTIAL DAMAGES. ALL IMPLIED WARRANTIES, INCLUDING THE IMPLIED WARRANTIES OF MERCHANTABILITY AND FITNESS, ARE LIMITED TO THE DURATION OF THIS WRITTEN WARRANTY. THIS WARRANTY SUPERCEDES ALL OTHER ORAL OR WRITTEN WARRANTIES.

Some states do not allow the exclusion or limitations of incidental and consequential damages or limitations on how long an implied warranty lasts, so the above limitations may not apply to you. This warranty gives you specific rights and you may have other rights which vary from state to state.

How to Obtain Service

If a defect is noted within the warranty period, the customer should contact a Vermont Castings Majestic Products Authorized Dealer or The Vermont Castings Majestic Products Company if the purchase was direct with the following information:

1. Name, address, and telephone number of the purchaser.
2. Date of purchase.
3. Model and Serial No. from the back of the stove.
4. Nature of the defect or damage.
5. Any relevant information or circumstances, e.g., installation, mode of operation when defect was noted.

A warranty claim process will then begin. The Vermont Castings Majestic Products Company reserves the right to withhold final approval of a warranty claim pending a visual inspection of the defect by authorized representatives.

Vermont Castings, Majestic Products

410 Admiral Blvd. • Mississauga, Ontario, Canada L5T 2N6 • 905-670-7777
www.vermontcastings.com • www.majesticproducts.com